

TAKT MAT

passion for automation

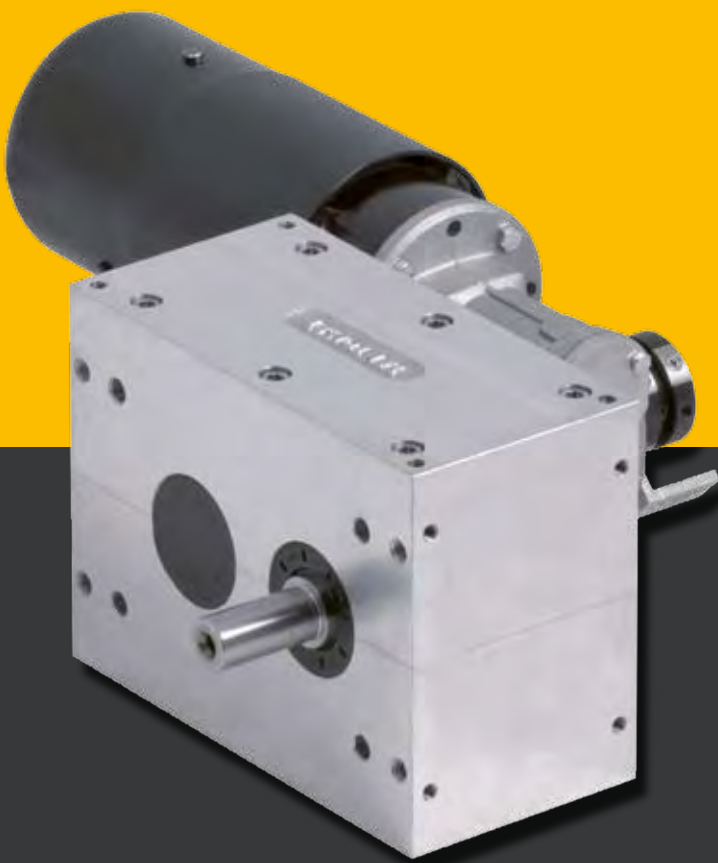

Parallel Indexers

Series XP and TP

Ready for peak performance

– with enthusiasm and courage for new solutions



Passion for Automation

... this motto sums up our company philosophy and our overall approach toward business. Our broad product range forms the basis for our highly individual and customized solutions. That basis also includes the full range of drives available to the market: Barrel cams, Flat cams, Globoidal cams and servo technology.

Calculations

J = moment of inertia - please download the TCC calculation software from www.taktomat.de

$$\epsilon = c_a \times \frac{2\pi}{n \times t^2}$$

$$M_B = J \times \epsilon$$

$$M_R = \mu \times g \times R \times m$$

$$M_{AB} = M_B + M_R + (M_{ST})^*$$

$$M_{ST} = m \times g \times R$$

$$M_{AN} = ((M_B \times c_m) + (M_{ST} \times c_v)) \times \frac{360^\circ}{n \times \alpha}$$

$$P = \frac{M_{AN} \times f_a}{9550 \times \eta}$$

*with one-sided lifting of loads (Paternoster)

J = moment of inertia [kgm²]

M_B = acceleration torque [Nm]

M_R = friction torque [Nm]

M_{AB} = engine torque [Nm]

M_{ST} = static torque [Nm]

M_{AN} = drive torque [Nm]

μ = friction coefficient

g = acceleration of gravity = 9,81m/s²

R = radius

m = mass [kg]

α = switching angle [°]

t_s = index time [s]

n = number of stopsl

i = ratio

P = drive power [kW]

η = efficiency worm gear

f_a = drive speed [1/min]

MS = acceleration form	MS0	MS30	MS50
c _a = acceleration coefficient	5,53	6,41	8,01
c _m = performance coefficient	0,99	0,81	0,72
c _v = speed coefficient	1,76	1,43	1,27

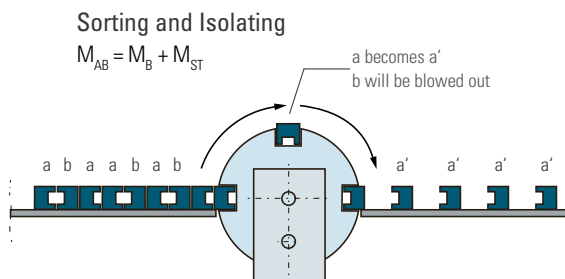

Application examples

Direct driven belt/chain

$$M_{AB} = M_B + M_R$$

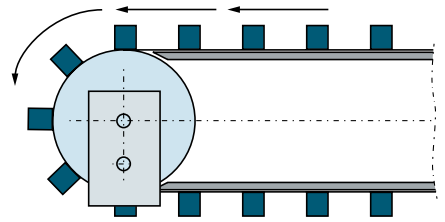

Indirect driven belt/chain

$$M_{AB} = \frac{M_B}{i^2} + \frac{M_R}{i}$$

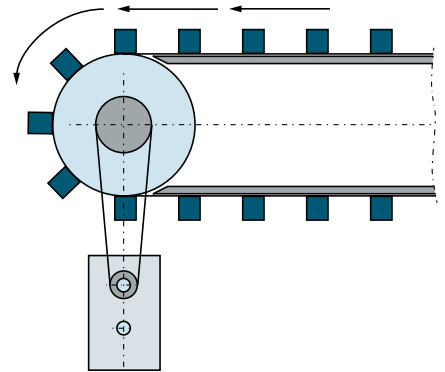

Arm

$$M_{AB} = M_B + M_{ST}$$

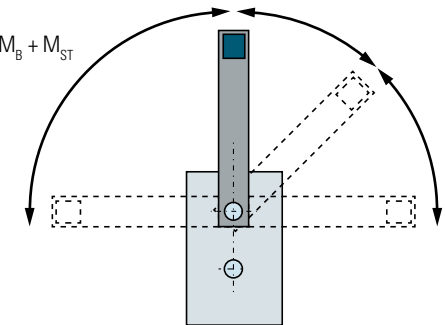

Transducer of rotations in horizontal movement

$$M_{AB} = M_B + M_R$$

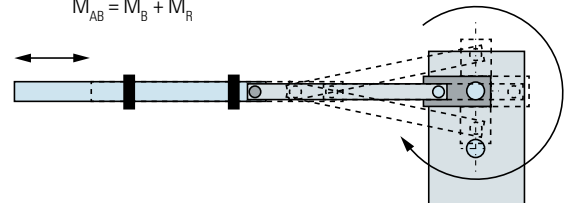

Rotate part

$$M_{AB} = M_B$$

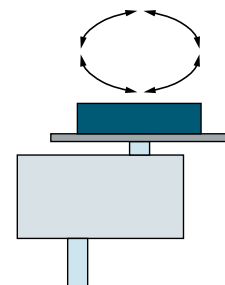

Load Table XP030

Angle on Output Shaft [°]	Number of Stops n	Switching Angle α [°]	Acceleration Form MS	Engine Torque M_{AB} [Nm]			Moment of Inertia J [kgm ²]			Index Time t_s [s]		
				n=50	n=100	n=200	n=50	n=100	n=200	n=50	n=100	n=200
360°	1	330	MS30	13	10	9	0,25	0,05	0,01	1,10	0,55	0,28
		300	MS50	13	10	9	0,26	0,05	0,01	1,00	0,50	0,25
180°	2	270	MS0	13	11	9	0,42	0,09	0,02	0,90	0,45	0,23
		210	MS30	13	10	8	0,29	0,06	0,01	0,70	0,35	0,18
		150	MS50	13	10	8	0,10	0,02	0,00	0,50	0,25	0,13
120°	3	270	MS0	17	14	12	0,95	0,20	0,04	0,90	0,45	0,23
		210	MS30	17	14	12	0,50	0,10	0,02	0,70	0,35	0,18
		150	MS30	16	13	11	0,24	0,05	0,01	0,50	0,25	0,13
		120	MS30	16	13	11	0,15	0,03	0,01	0,40	0,20	0,10
90°	4	270	MS0	13	13	11	0,97	0,24	0,05	0,90	0,45	0,23
		210	MS0	13	13	11	0,59	0,15	0,03	0,70	0,35	0,18
		150	MS30	12	12	10	0,24	0,06	0,01	0,50	0,25	0,13
		90	MS30	11	11	9	0,08	0,02	0,00	0,30	0,15	0,08
72°	5	270	MS0	13	13	11	1,21	0,30	0,06	0,90	0,45	0,23
		210	MS0	13	13	11	0,73	0,18	0,04	0,70	0,35	0,18
		150	MS30	12	12	10	0,30	0,07	0,02	0,50	0,25	0,13
		90	MS30	11	11	9	0,10	0,02	0,01	0,30	0,15	0,08
60°	6 ¹⁾	270	MS0	16	16	12	1,79	0,45	0,08	0,90	0,45	0,23
		240	MS0	16	16	12	1,42	0,35	0,07	0,80	0,40	0,20
		180	MS30	15	15	11	0,64	0,16	0,03	0,60	0,30	0,15
		120	MS30	13	13	10	0,25	0,06	0,01	0,40	0,20	0,10
45°	8 ¹⁾	270	MS0	12	12	11	1,79	0,45	0,10	0,90	0,45	0,23
		240	MS0	12	12	11	1,42	0,35	0,08	0,80	0,40	0,20
		180	MS30	12	12	11	0,69	0,17	0,04	0,60	0,30	0,15
		120	MS30	11	11	10	0,28	0,07	0,02	0,40	0,20	0,10

¹⁾ Parallel gears with stop numbers 6, 8 and 10 are designed as a double indexer, i.e. with each full rotation of the drive shaft, two indexes occur in the output.

²⁾ Parallel gears with 12 stops are designed as a four step indexer, i.e. with each full rotation of the drive shaft, four indexes occur in the output.

³⁾ The additional load occurring with chains and belts due to friction is not taken into consideration here and must be calculated separately.

Technical Specifications

Main Dimensions

Shaft distance [mm]	30
Weight without drive [kg]	0,7
Switching angle [°]	see Load Table (other switching angles upon request)
Numbers of stops	1, 2, 3, 4, 5, 6, 8 (other numbers of stops upon request)
Rotating Direction	right, left, oscillating

Capacities

Max. Output torque	see Load Table
Input Shaft	
Load rating dynamic [kN]	1,38
Load rating static [kN]	0,58
Output shaft	
Load rating dynamic [kN]	1,38
Load rating static [kN]	0,58

Standard without drive

XP040

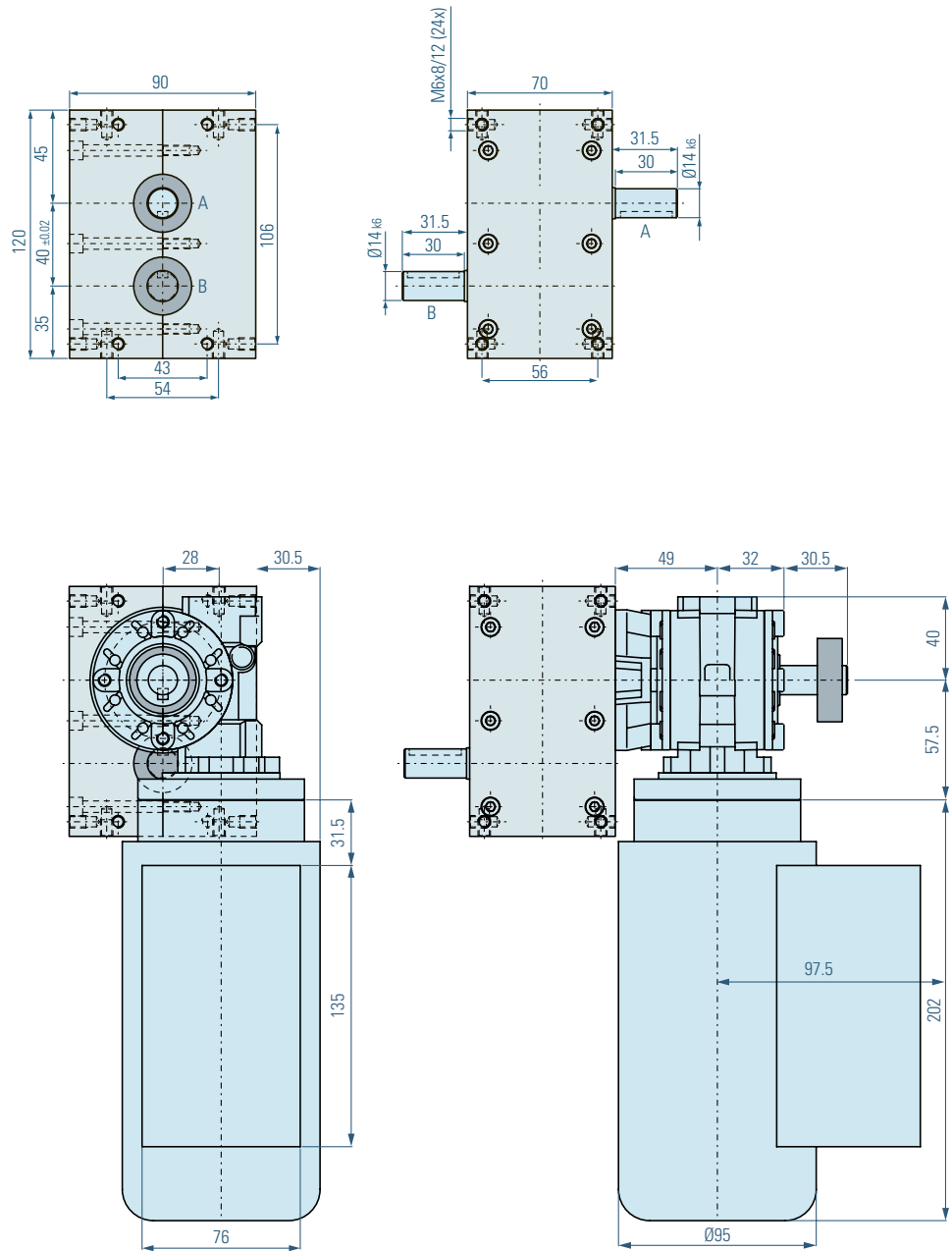

Dimensions

The measurements shown here illustrate the standard version. We will gladly customize the housing and the two shafts to suit your needs. The drive shaft as well as the output shaft is available as

double sided shafts with and without feather gear groove. If you would like to add additional boreholes into the housing yourself, please contact us for possible drilling depths.

- ⚠ Warning! Never drill through the housing.
- ⚠ Warning! Depending on the drive size used, the dimensions of the engine and drive may change.

A = Drive Shaft B = Output Shaft

Load Table XP040

Angle on Output Shaft [°]	Number of Stops n	Switching Angle α [°]	Acceleration Form MS	Engine Torque M_{AB} [Nm]			Moment of Inertia J [kgm ²]			Index Time t_s [s]		
				n=50	n=100	n=200	n=50	n=100	n=200	n=50	n=100	n=200
360°	1	330	MS30	29	25	21	0,56	0,12	0,03	1,10	0,55	0,28
		300	MS50	28	24	20	0,56	0,12	0,02	1,00	0,50	0,25
180°	2	270	MS0	32	27	24	1,03	0,22	0,05	0,90	0,45	0,23
		210	MS30	26	24	21	0,59	0,14	0,03	0,70	0,35	0,18
		150	MS50	25	23	20	0,20	0,05	0,01	0,50	0,25	0,13
120°	3	270	MS0	39	33	26	2,18	0,46	0,09	0,90	0,45	0,23
		210	MS30	39	33	26	1,14	0,24	0,05	0,70	0,35	0,18
		150	MS30	33	27	23	0,49	0,10	0,02	0,50	0,25	0,13
		120	MS30	30	25	20	0,29	0,06	0,01	0,40	0,20	0,10
90°	4	270	MS0	36	30	24	2,69	0,56	0,11	0,90	0,45	0,23
		210	MS0	36	30	24	1,63	0,34	0,07	0,70	0,35	0,18
		150	MS30	35	29	23	0,70	0,14	0,03	0,50	0,25	0,13
		90	MS30	32	28	21	0,23	0,05	0,01	0,30	0,15	0,08
72°	5	270	MS0	36	30	24	3,36	0,70	0,14	0,90	0,45	0,23
		210	MS0	36	30	24	2,03	0,42	0,08	0,70	0,35	0,18
		150	MS30	35	29	23	0,87	0,18	0,04	0,50	0,25	0,13
		90	MS30	32	28	21	0,29	0,06	0,01	0,30	0,15	0,08
60°	6 ¹⁾	270	MS0	42	34	28	4,70	0,95	0,20	0,90	0,45	0,23
		240	MS0	42	34	28	3,72	0,75	0,15	0,80	0,40	0,20
		180	MS30	40	32	25	1,72	0,34	0,07	0,60	0,30	0,15
		120	MS30	36	29	22	0,69	0,14	0,03	0,40	0,20	0,10
45°	8 ¹⁾	270	MS0	42	34	28	6,27	1,27	0,26	0,90	0,45	0,23
		240	MS0	42	34	28	4,95	1,00	0,21	0,80	0,40	0,20
		180	MS30	40	32	25	2,29	0,46	0,09	0,60	0,30	0,15
		120	MS30	36	29	22	0,92	0,18	0,03	0,40	0,20	0,10
36	10 ¹⁾	270	MS0	42	34	28	7,84	1,59	0,33	0,90	0,45	0,23
		240	MS0	42	34	28	6,19	1,25	0,26	0,80	0,40	0,20
		180	MS30	40	32	25	2,86	0,57	0,11	0,60	0,30	0,15
		120	MS30	36	29	22	1,14	0,23	0,04	0,40	0,20	0,10

¹⁾ Parallel gears with stop numbers 6, 8 and 10 are designed as a double indexer, i.e. with each full rotation of the drive shaft, two indexes occur in the output.

²⁾ Parallel gears with 12 stops are designed as a four step indexer, i.e. with each full rotation of the drive shaft, four indexes occur in the output.

³⁾ The additional load occurring with chains and belts due to friction is not taken into consideration here and must be calculated separately.

Technical Specifications

Main Dimensions

Shaft distance [mm]	40
Weight without drive [kg]	2
Switching angle [°] (other switching angles upon request)	see Load Table
Numbers of stops (other numbers of stops upon request)	1, 2, 3, 4, 5, 6, 8, 10
Rotating Direction	right, left, oscillating

Capacities

Max. Output torque	see Load Table
Input Shaft	
Load rating dynamic [kN]	4,36
Load rating static [kN]	2,24
Output shaft	
Load rating dynamic [kN]	4,36
Load rating static [kN]	2,24

Standard drive (optional)

Motor	SEW oder Kobold
Worm Gear	FRS28
Frame Size	IEC56
Voltage [V]	230/400
Performance [kW]	0,06-0,09

XP050

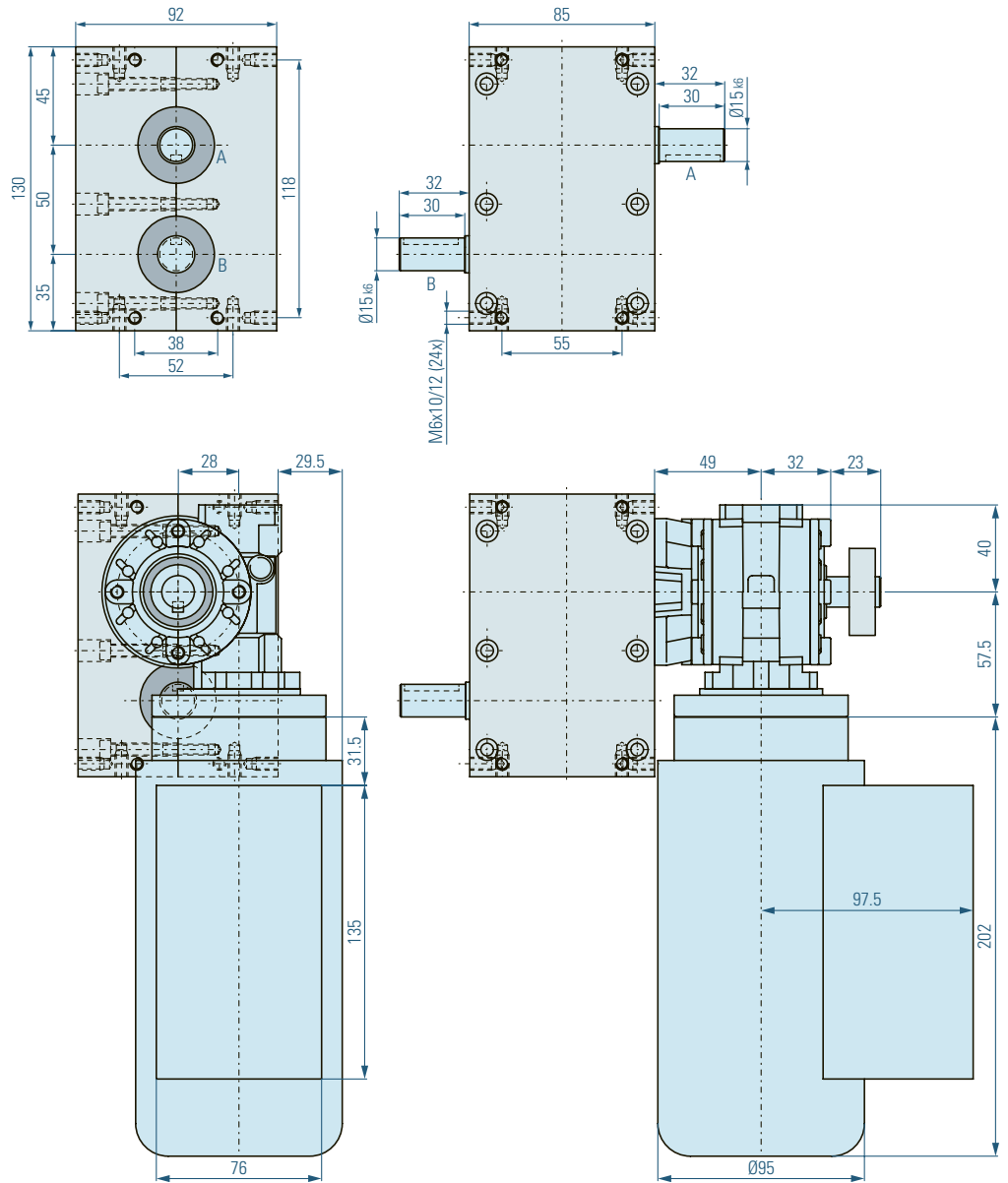

Dimensions

The measurements shown here illustrate the standard version. We will gladly customize the housing and the two shafts to suit your needs. The drive shaft as well as the output shaft is available as

double sided shafts with and without feather gear groove. If you would like to add additional boreholes into the housing yourself, please contact us for possible drilling depths.

- ⚠ Warning! Never drill through the housing.
- ⚠ Warning! Depending on the drive size used, the dimensions of the engine and drive may change.

A = Drive Shaft B = Output Shaft

Load Table XP050

Angle on Output Shaft [°]	Number of Stops n	Switching Angle α [°]	Acceleration Form MS	Engine Torque M_{AB} [Nm]			Moment of Inertia J [kgm ²]			Index Time t_s [s]		
				n=50	n=100	n=200	n=50	n=100	n=200	n=50	n=100	n=200
360°	1	330	MS30	41	34	29	0,79	0,16	0,03	1,10	0,55	0,28
		300	MS50	41	34	29	0,81	0,17	0,04	1,00	0,50	0,25
180°	2	270	MS0	51	43	37	1,64	0,35	0,07	0,90	0,45	0,23
		210	MS30	49	42	36	1,11	0,24	0,05	0,70	0,35	0,18
		150	MS50	42	37	34	0,33	0,07	0,02	0,50	0,25	0,13
120°	3	270	MS0	54	49	43	3,02	0,69	0,15	0,90	0,45	0,23
		210	MS30	52	47	42	1,52	0,34	0,08	0,70	0,35	0,18
		150	MS30	45	40	33	0,67	0,15	0,03	0,50	0,25	0,13
		120	MS30	43	37	31	0,41	0,09	0,02	0,40	0,20	0,10
90°	4	270	MS0	47	43	38	3,51	0,80	0,18	0,90	0,45	0,23
		210	MS0	45	41	35	2,03	0,46	0,10	0,70	0,35	0,18
		150	MS30	41	37	31	0,81	0,18	0,04	0,50	0,25	0,13
		90	MS30	37	31	26	0,26	0,06	0,01	0,30	0,15	0,08
72°	5	270	MS0	47	43	38	4,38	1,00	0,22	0,90	0,45	0,23
		210	MS0	45	41	35	2,54	0,58	0,12	0,70	0,35	0,18
		150	MS30	41	37	31	1,02	0,23	0,05	0,50	0,25	0,13
		90	MS30	37	31	26	0,33	0,07	0,01	0,30	0,15	0,08
60°	6 ¹⁾	270	MS0	59	57	53	6,61	1,60	0,37	0,90	0,45	0,23
		240	MS0	58	54	50	5,13	1,19	0,28	0,80	0,40	0,20
		180	MS30	50	46	41	2,15	0,49	0,11	0,60	0,30	0,15
		120	MS30	47	41	38	0,90	0,20	0,05	0,40	0,20	0,10
45°	8 ¹⁾	270	MS0	59	57	53	8,81	2,13	0,49	0,90	0,45	0,23
		240	MS0	58	54	50	6,84	1,59	0,37	0,80	0,40	0,20
		180	MS30	50	46	41	2,86	0,66	0,15	0,60	0,30	0,15
		120	MS30	47	41	38	1,20	0,26	0,06	0,40	0,20	0,10
36°	10 ¹⁾	270	MS0	59	57	53	11,01	2,66	0,62	0,90	0,45	0,23
		240	MS0	58	54	50	8,55	1,99	0,46	0,80	0,40	0,20
		180	MS30	50	46	41	3,58	0,82	0,18	0,60	0,30	0,15
		120	MS30	47	41	38	1,49	0,33	0,08	0,40	0,20	0,10
30°	12 ²⁾	240	MS0	41	38	31	7,25	1,68	0,34	0,80	0,40	0,20

¹⁾ Parallel gears with stop numbers 6, 8 and 10 are designed as a double indexer, i.e. with each full rotation of the drive shaft, two indexes occur in the output.

²⁾ Parallel gears with 12 stops are designed as a four step indexer, i.e. with each full rotation of the drive shaft, four indexes occur in the output.

³⁾ The additional load occurring with chains and belts due to friction is not taken into consideration here and must be calculated separately.

Technical Specifications

Main Dimensions

Shaft distance [mm]	50
Weight without drive [kg]	2,5
Switching angle [°] (other switching angles upon request)	see Load Table
Numbers of stops (other numbers of stops upon request)	1, 2, 3, 4, 5, 6, 8, 10, 12
Rotating Direction	right, left, oscillating

Capacities

Max. Output torque	see Load Table
Input Shaft	
Load rating dynamic [kN]	6,37
Load rating static [kN]	3,25
Output shaft	
Load rating dynamic [kN]	6,37
Load rating static [kN]	3,25

Standard drive (optional)

Motor	SEW oder Kobold
Worm Gear	FRS28
Frame Size	IEC56
Voltage [V]	230/400
Performance [kW]	0,06-0,09

XP065

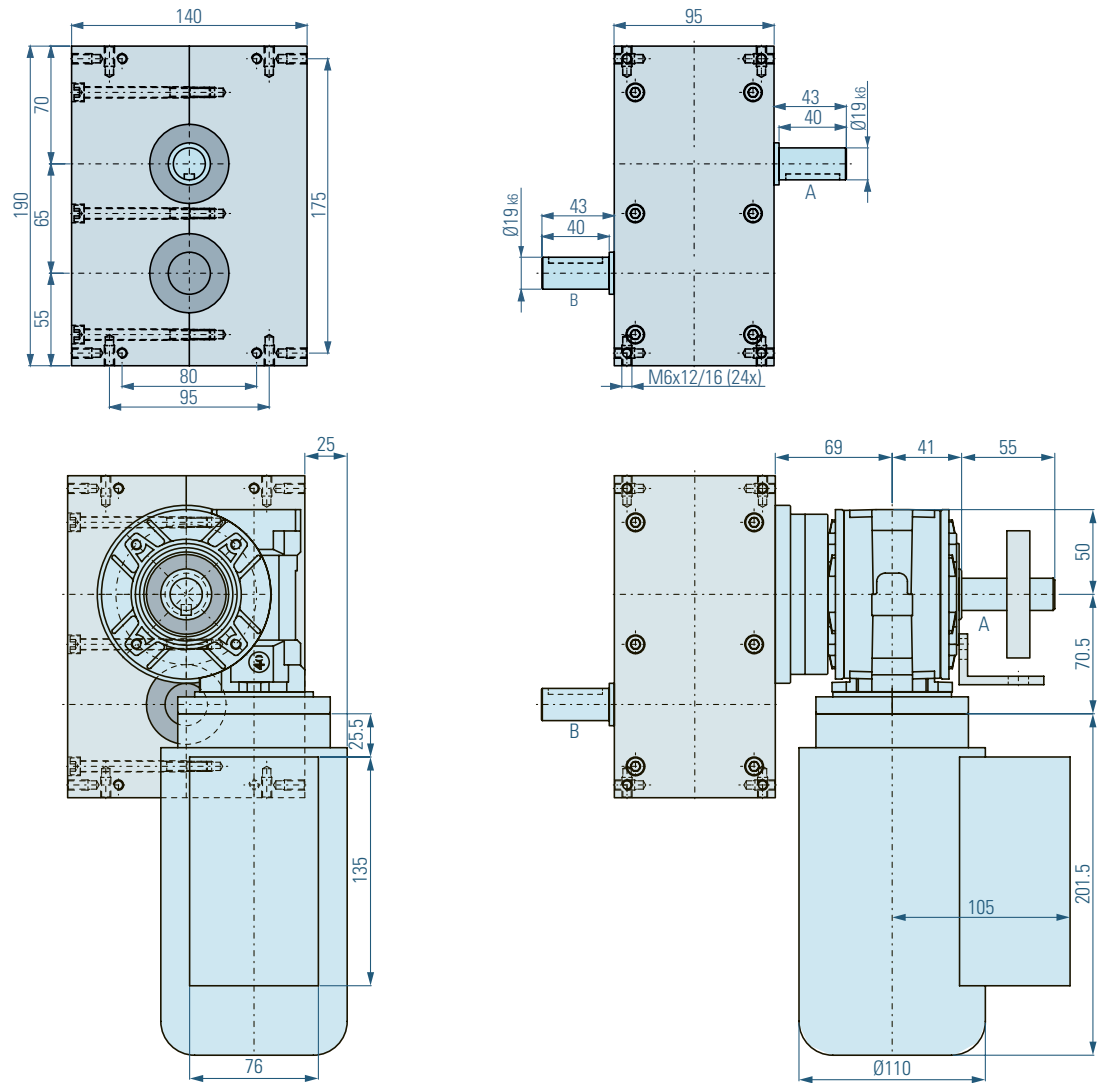

Dimensions

The measurements shown here illustrate the standard version. We will gladly customize the housing and the two shafts to suit your needs. The drive shaft as well as the output shaft is available as

double sided shafts with and without feather gear groove. If you would like to add additional boreholes into the housing yourself, please contact us for possible drilling depths.

- ⚠ Warning! Never drill through the housing.
- ⚠ Warning! Depending on the drive size used, the dimensions of the engine and drive may change.

A = Drive Shaft B = Output Shaft

Load Table XP065

Angle on Output Shaft [°]	Number of Stops n	Switching Angle α [°]	Acceleration Form MS	Engine Torque M_{AB} [Nm]			Moment of Inertia J [kgm ²]			Index Time t_s [s]		
				n=50	n=100	n=200	n=50	n=100	n=200	n=50	n=100	n=200
360°	1	330	MS30	52	43	36	1,0	0,2	0,04	1,10	0,55	0,28
		300	MS50	48	39	30	1,0	0,2	0,04	1,00	0,50	0,25
180°	2	270	MS0	58	51	43	1,9	0,4	0,09	0,90	0,45	0,23
		210	MS30	48	46	41	1,1	0,3	0,06	0,70	0,35	0,18
		150	MS50	42	40	39	0,3	0,1	0,02	0,50	0,25	0,13
120°	3	270	MS0	74	68	59	4,1	1,0	0,21	0,90	0,45	0,23
		210	MS30	73	67	57	2,1	0,5	0,10	0,70	0,35	0,18
		150	MS30	61	53	46	0,9	0,2	0,04	0,50	0,25	0,13
		120	MS30	60	52	43	0,6	0,1	0,03	0,40	0,20	0,10
90°	4	270	MS0	68	61	53	5,1	1,1	0,25	0,90	0,45	0,23
		210	MS0	66	59	51	3,0	0,7	0,14	0,70	0,35	0,18
		150	MS30	64	57	49	1,3	0,3	0,06	0,50	0,25	0,13
		90	MS30	64	57	49	0,5	0,1	0,02	0,30	0,15	0,08
72°	5	270	MS0	68	61	53	6,3	1,4	0,31	0,90	0,45	0,23
		210	MS0	66	59	51	3,7	0,8	0,18	0,70	0,35	0,18
		150	MS30	64	57	49	1,6	0,4	0,08	0,50	0,25	0,13
		90	MS30	64	57	49	0,6	0,1	0,03	0,30	0,15	0,08
60°	6 ¹⁾	270	MS0	86	71	56	9,6	2,0	0,39	0,90	0,45	0,23
		240	MS0	83	69	54	7,3	1,5	0,30	0,80	0,40	0,20
		180	MS30	79	65	51	3,4	0,7	0,14	0,60	0,30	0,15
		120	MS30	75	61	46	1,4	0,3	0,05	0,40	0,20	0,10
45°	8 ¹⁾	270	MS0	86	71	56	12,8	2,6	0,52	0,90	0,45	0,23
		240	MS0	83	69	54	9,8	2,0	0,40	0,80	0,40	0,20
		180	MS30	79	65	51	4,5	0,9	0,18	0,60	0,30	0,15
		120	MS30	75	61	46	1,9	0,4	0,07	0,40	0,20	0,10
36°	10 ¹⁾	270	MS0	86	71	56	16,0	3,3	0,65	0,90	0,45	0,23
		240	MS0	83	69	54	12,2	2,5	0,50	0,80	0,40	0,20
		180	MS30	79	65	51	5,7	1,2	0,23	0,60	0,30	0,15
		120	MS30	75	61	46	2,4	0,5	0,09	0,40	0,20	0,10
30°	12 ²⁾	240	MS0	62	51	39	11,0	2,3	0,43	0,80	0,40	0,20

¹⁾ Parallel gears with stop numbers 6, 8 and 10 are designed as a double indexer, i.e. with each full rotation of the drive shaft, two indexes occur in the output.

²⁾ Parallel gears with 12 stops are designed as a four step indexer, i.e. with each full rotation of the drive shaft, four indexes occur in the output.

³⁾ The additional load occurring with chains and belts due to friction is not taken into consideration here and must be calculated separately.

Technical Specifications

Main Dimensions

Shaft distance [mm]	65
Weight without drive [kg]	8
Switching angle [°] (other switching angles upon request)	see Load Table
Numbers of stops (other numbers of stops upon request)	1, 2, 3, 4, 5, 6, 8, 10, 12
Rotating Direction	right, left, oscillating

Capacities

Max. Output torque	see Load Table
Input Shaft	
Load rating dynamic [kN]	11,9
Load rating static [kN]	6,55
Output shaft	
Load rating dynamic [kN]	11,9
Load rating static [kN]	6,55

Standard drive (optional)

Motor	SEW oder Kobold
Worm Gear	FRS40
Frame Size	IEC63
Voltage [V]	230/400
Performance [kW]	0,12-0,25

XP080

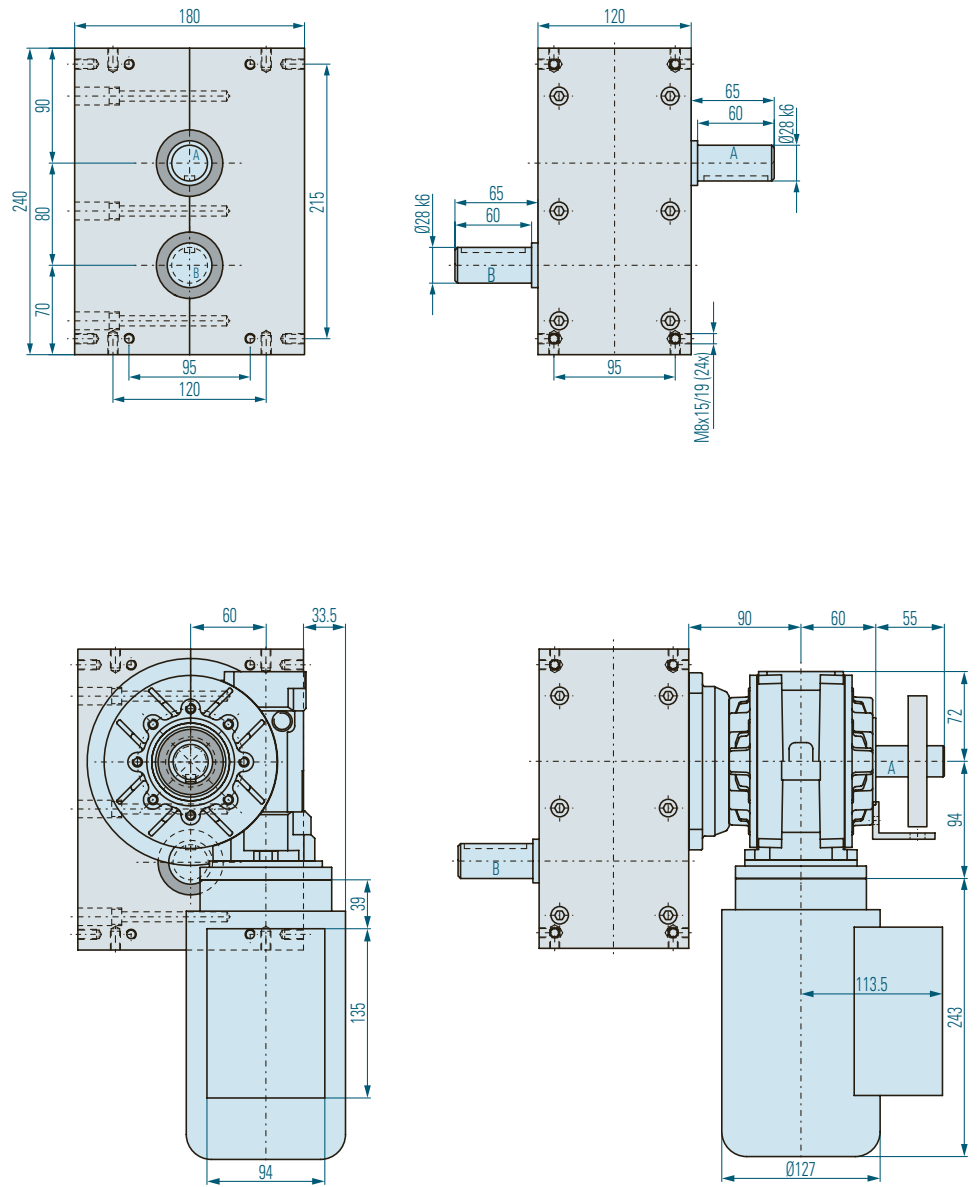

Dimensions

The measurements shown here illustrate the standard version. We will gladly customize the housing and the two shafts to suit your needs. The drive shaft as well as the output shaft is available as

double sided shafts with and without feather gear groove. If you would like to add additional boreholes into the housing yourself, please contact us for possible drilling depths.

- ⚠ Warning! Never drill through the housing.
- ⚠ Warning! Depending on the drive size used, the dimensions of the engine and drive may change.

A = Drive Shaft B = Output Shaft

Load Table XP080

Angle on Output Shaft [°]	Number of Stops n	Switching Angle α [°]	Acceleration Form MS	Engine Torque M_{AB} [Nm]			Moment of Inertia J [kgm ²]			Index Time t_s [s]		
				n=50	n=100	n=200	n=50	n=100	n=200	n=50	n=100	n=200
360°	1	330	MS30	124	102	81	2,4	0,5	0,10	1,10	0,55	0,28
		300	MS50	123	101	79	2,4	0,5	0,10	1,00	0,50	0,25
180°	2	270	MS0	132	107	93	4,2	0,9	0,19	0,90	0,45	0,23
		210	MS30	131	107	93	3,0	0,6	0,13	0,70	0,35	0,18
		150	MS50	103	96	89	0,8	0,2	0,04	0,50	0,25	0,13
120°	3	270	MS0	159	137	112	8,9	1,9	0,39	0,90	0,45	0,23
		210	MS30	152	129	101	4,4	0,9	0,18	0,70	0,35	0,18
		150	MS30	127	103	83	1,9	0,4	0,08	0,50	0,25	0,13
		120	MS30	119	97	78	1,1	0,2	0,05	0,40	0,20	0,10
90°	4	270	MS0	157	132	109	11,7	2,5	0,51	0,90	0,45	0,23
		210	MS0	151	126	96	6,8	1,4	0,27	0,70	0,35	0,18
		150	MS30	138	112	88	2,7	0,6	0,11	0,50	0,25	0,13
		90	MS30	118	92	76	0,8	0,2	0,03	0,30	0,15	0,08
72°	5	270	MS0	157	132	109	14,6	3,1	0,64	0,90	0,45	0,23
		210	MS0	151	126	96	8,5	1,8	0,34	0,70	0,35	0,18
		150	MS30	138	112	88	3,4	0,7	0,14	0,50	0,25	0,13
		90	MS30	118	92	76	1,1	0,2	0,04	0,30	0,15	0,08
60°	6 ¹⁾	270	MS0	186	149	124	20,8	4,2	0,87	0,90	0,45	0,23
		240	MS0	174	146	120	15,4	3,2	0,66	0,80	0,40	0,20
		180	MS30	160	122	96	6,9	1,3	0,26	0,60	0,30	0,15
		120	MS30	132	105	81	2,5	0,5	0,10	0,40	0,20	0,10
45°	8 ¹⁾	270	MS0	186	149	124	27,8	5,6	1,16	0,90	0,45	0,23
		240	MS0	174	146	120	20,5	4,3	0,88	0,80	0,40	0,20
		180	MS30	160	122	96	9,2	1,7	0,34	0,60	0,30	0,15
		120	MS30	132	105	81	3,4	0,7	0,13	0,40	0,20	0,10
36°	10 ¹⁾	270	MS0	186	149	124	34,7	7,0	1,45	0,90	0,45	0,23
		240	MS0	174	146	120	25,7	5,4	1,11	0,80	0,40	0,20
		180	MS30	160	122	96	11,4	2,2	0,43	0,60	0,30	0,15
		120	MS30	132	105	81	4,2	0,8	0,16	0,40	0,20	0,10
30°	12 ²⁾	240	MS0	110	95	76	19,5	4,2	0,84	0,80	0,40	0,20

¹⁾ Parallel gears with stop numbers 6, 8 and 10 are designed as a double indexer, i.e. with each full rotation of the drive shaft, two indexes occur in the output.

²⁾ Parallel gears with 12 stops are designed as a four step indexer, i.e. with each full rotation of the drive shaft, four indexes occur in the output.

³⁾ The additional load occurring with chains and belts due to friction is not taken into consideration here and must be calculated separately.

Technical Specifications

Main Dimensions

Shaft distance [mm]	80
Weight without drive [kg]	12
Switching angle [°]	see Load Table (other switching angles upon request)
Numbers of stops	1, 2, 3, 4, 5, 6, 8, 10, 12 (other numbers of stops upon request)
Rotating Direction	right, left, oscillating

Capacities

Max. Output torque	see Load Table
Input Shaft	
Load rating dynamic [kN]	13,8
Load rating static [kN]	8,3
Output shaft	
Load rating dynamic [kN]	13,8
Load rating static [kN]	8,3

Standard drive (optional)

Motor	SEW oder Kobold
Worm Gear	FRS60
Frame Size	IEC71
Voltage [V]	230/400
Performance [kW]	0,37

XP105

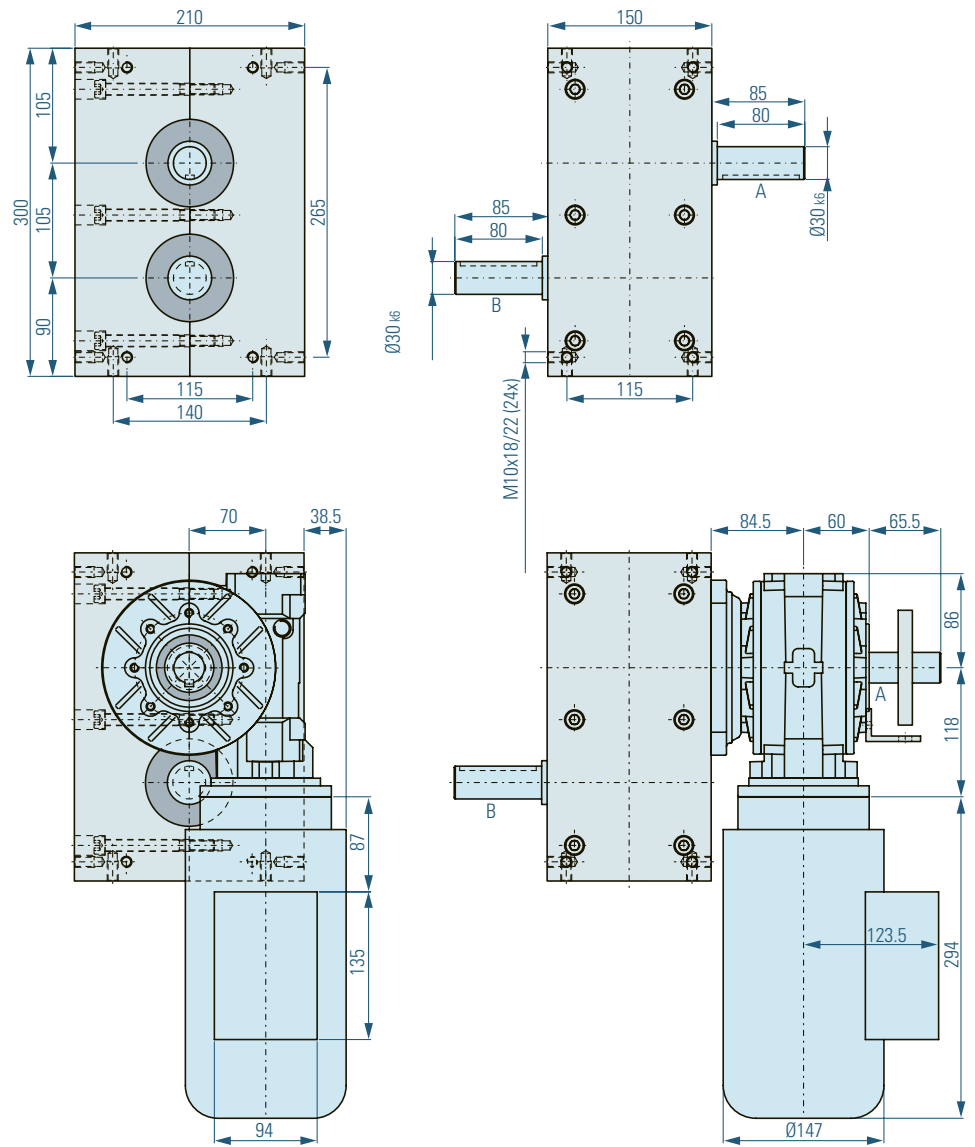

Dimensions

The measurements shown here illustrate the standard version. We will gladly customize the housing and the two shafts to suit your needs. The drive shaft as well as the output shaft is available as

double sided shafts with and without feather gear groove. If you would like to add additional boreholes into the housing yourself, please contact us for possible drilling depths.

- ⚠ Warning! Never drill through the housing.
- ⚠ Warning! Depending on the drive size used, the dimensions of the engine and drive may change.

A = Drive Shaft B = Output Shaft

Load Table XP105

Angle on Output Shaft [°]	Number of Stops n	Switching Angle α [°]	Acceleration Form MS	Engine Torque M_{AB} [Nm]			Moment of Inertia J [kgm ²]			Index Time t_s [s]		
				n=50	n=100	n=200	n=50	n=100	n=200	n=50	n=100	n=200
360°	1	330	MS30	216	175	138	4,2	0,8	0,2	1,10	0,55	0,28
		300	MS50	208	171	132	4,1	0,8	0,2	1,00	0,50	0,25
180°	2	270	MS0	297	265	230	9,6	2,1	0,5	0,90	0,45	0,23
		210	MS30	285	251	221	6,4	1,4	0,3	0,70	0,35	0,18
		150	MS50	254	204	155	2,0	0,4	0,1	0,50	0,25	0,13
120°	3	270	MS0	361	319	278	20,2	4,5	1,0	0,90	0,45	0,23
		210	MS30	350	312	270	10,2	2,3	0,5	0,70	0,35	0,18
		150	MS30	344	306	261	5,1	1,1	0,2	0,50	0,25	0,13
		120	MS30	340	301	256	3,2	0,7	0,2	0,40	0,20	0,10
90°	4	270	MS0	341	298	245	25,5	5,6	1,1	0,90	0,45	0,23
		210	MS0	330	291	238	14,9	3,3	0,7	0,70	0,35	0,18
		150	MS30	318	279	226	6,3	1,4	0,3	0,50	0,25	0,13
		90	MS30	292	269	221	2,1	0,5	0,1	0,30	0,15	0,08
72°	5	270	MS0	341	298	245	31,8	7,0	1,4	0,90	0,45	0,23
		210	MS0	330	291	238	18,6	4,1	0,8	0,70	0,35	0,18
		150	MS30	318	279	226	7,9	1,7	0,4	0,50	0,25	0,13
		90	MS30	292	269	221	2,6	0,6	0,1	0,30	0,15	0,08
60°	6 ¹⁾	270	MS0	391	351	298	43,8	9,8	2,1	0,90	0,45	0,23
		240	MS0	377	339	286	33,3	7,5	1,6	0,80	0,40	0,20
		180	MS30	305	260	202	13,1	2,8	0,5	0,60	0,30	0,15
		120	MS30	281	239	180	5,4	1,1	0,2	0,40	0,20	0,10
45°	8 ¹⁾	270	MS0	391	351	298	58,4	13,1	2,8	0,90	0,45	0,23
		240	MS0	377	339	286	44,5	10,0	2,1	0,80	0,40	0,20
		180	MS30	305	260	202	17,5	3,7	0,7	0,60	0,30	0,15
		120	MS30	281	239	180	7,1	1,5	0,3	0,40	0,20	0,10
36°	10 ¹⁾	270	MS0	391	351	298	73,0	16,4	3,5	0,90	0,45	0,23
		240	MS0	377	339	286	55,6	12,5	2,6	0,80	0,40	0,20
		180	MS30	305	260	202	21,8	4,7	0,9	0,60	0,30	0,15
		120	MS30	281	239	180	8,9	1,9	0,4	0,40	0,20	0,10
30°	12 ²⁾	240	MS0	270	220	170	47,8	9,7	1,9	0,80	0,40	0,20

¹⁾ Parallel gears with stop numbers 6, 8 and 10 are designed as a double indexer, i.e. with each full rotation of the drive shaft, two indexes occur in the output.

²⁾ Parallel gears with 12 stops are designed as a four step indexer, i.e. with each full rotation of the drive shaft, four indexes occur in the output.

³⁾ The additional load occurring with chains and belts due to friction is not taken into consideration here and must be calculated separately.

Technical Specifications

Main Dimensions

Shaft distance [mm]	105
Weight without drive [kg]	32
Switching angle [°]	see Load Table (other switching angles upon request)
Numbers of stops	1, 2, 3, 4, 5, 6, 8, 10, 12 (other numbers of stops upon request)
Rotating Direction	right, left, oscillating

Capacities

Max. Output torque	see Load Table
Input Shaft	
Load rating dynamic [kN]	30,7
Load rating static [kN]	19
Output shaft	
Load rating dynamic [kN]	30,7
Load rating static [kN]	19

Standard drive (optional)

Motor	SEW oder Kobold
Worm Gear	FRS70
Frame Size	IEC80
Voltage [V]	230/400
Performance [kW]	0,55-0,75

XP130

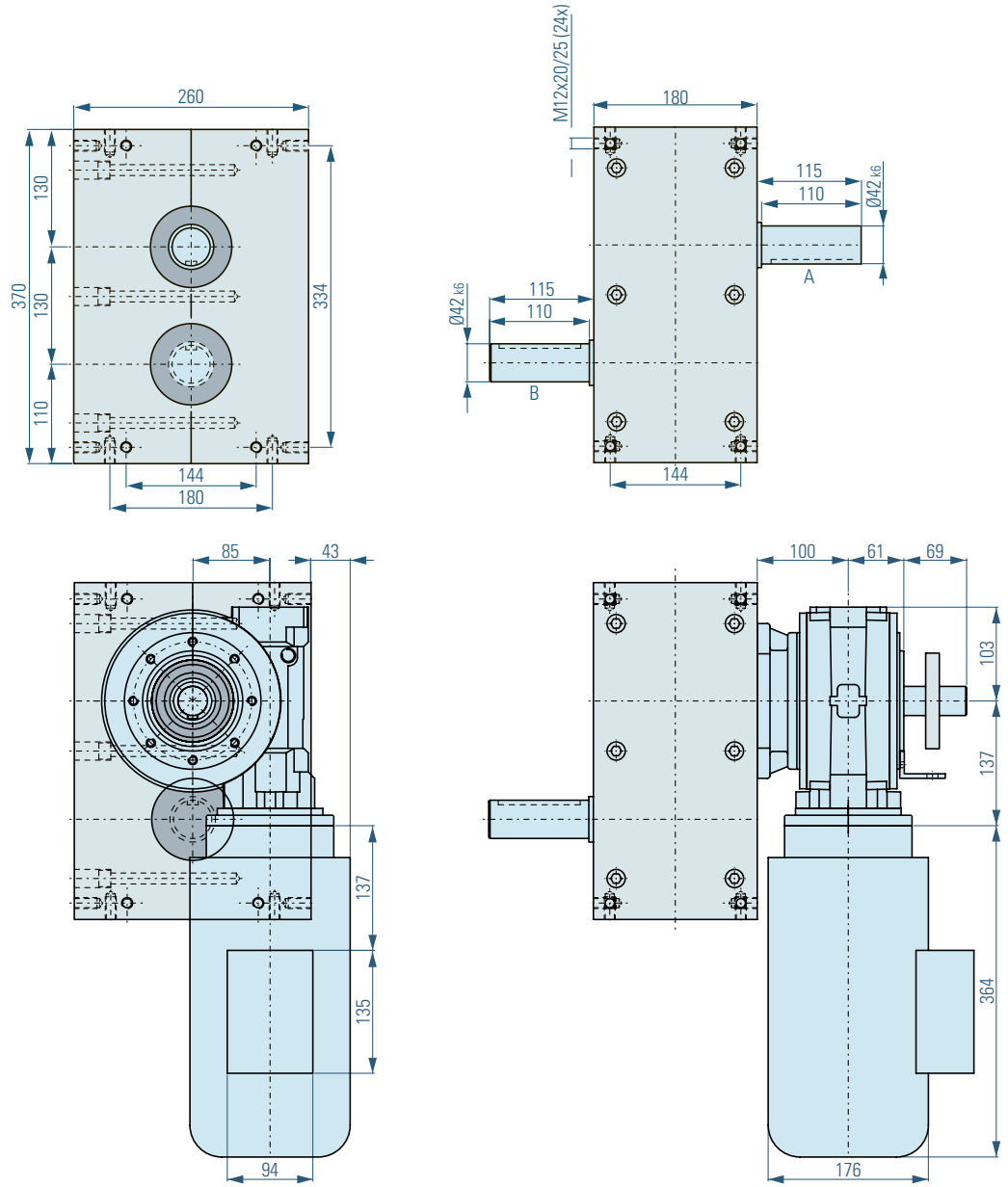

Dimensions

The measurements shown here illustrate the standard version. We will gladly customize the housing and the two shafts to suit your needs. The drive shaft as well as the output shaft is available as

double sided shafts with and without feather gear groove. If you would like to add additional boreholes into the housing yourself, please contact us for possible drilling depths.

- ⚠ Warning! Never drill through the housing.
- ⚠ Warning! Depending on the drive size used, the dimensions of the engine and drive may change.

A = Drive Shaft B = Output Shaft

Load Table XP130

Angle on Output Shaft [°]	Number of Stops n	Switching Angle α [°]	Acceleration Form MS	Engine Torque M_{AB} [Nm]			Moment of Inertia J [kgm ²]			Index Time t_s [s]		
				n=50	n=100	n=200	n=50	n=100	n=200	n=50	n=100	n=200
360°	1	330	MS30	359	290	227	6,9	1,4	0,3	1,10	0,55	0,28
		300	MS50	350	278	210	7,0	1,4	0,3	1,00	0,50	0,25
180°	2	270	MS0	449	370	302	14,5	3,0	0,6	0,90	0,45	0,23
		210	MS30	372	283	213	8,4	1,6	0,3	0,70	0,35	0,18
		150	MS50	310	228	165	2,5	0,5	0,1	0,50	0,25	0,13
120°	3	270	MS0	554	460	375	31,0	6,4	1,3	0,90	0,45	0,23
		210	MS30	520	436	360	15,2	3,2	0,7	0,70	0,35	0,18
		150	MS30	415	330	240	6,2	1,2	0,2	0,50	0,25	0,13
		120	MS30	390	285	210	3,7	0,7	0,1	0,40	0,20	0,10
90°	4	270	MS0	540	455	360	40,3	8,5	1,7	0,90	0,45	0,23
		210	MS0	501	413	325	22,6	4,7	0,9	0,70	0,35	0,18
		150	MS30	480	390	294	9,5	1,9	0,4	0,50	0,25	0,13
		90	MS30	440	346	263	3,1	0,6	0,1	0,30	0,15	0,08
72°	5	270	MS0	540	455	360	50,4	10,6	2,1	0,90	0,45	0,23
		210	MS0	501	413	325	28,3	5,8	1,1	0,70	0,35	0,18
		150	MS30	480	390	294	11,9	2,4	0,5	0,50	0,25	0,13
		90	MS30	440	346	263	3,9	0,8	0,1	0,30	0,15	0,08
60°	6 ¹⁾	270	MS0	615	537	442	68,9	15,0	3,1	0,90	0,45	0,23
		240	MS0	576	483	390	51,0	10,7	2,2	0,80	0,40	0,20
		180	MS30	445	368	280	19,1	3,9	0,8	0,60	0,30	0,15
		120	MS30	395	320	239	7,5	1,5	0,3	0,40	0,20	0,10
45°	8 ¹⁾	270	MS0	615	537	442	91,8	20,0	4,1	0,90	0,45	0,23
		240	MS0	576	483	390	67,9	14,2	2,9	0,80	0,40	0,20
		180	MS30	445	368	280	25,5	5,3	1,0	0,60	0,30	0,15
		120	MS30	395	320	239	10,0	2,0	0,4	0,40	0,20	0,10
36°	10 ¹⁾	270	MS0	615	537	442	114,8	25,0	5,2	0,90	0,45	0,23
		240	MS0	576	483	390	84,9	17,8	3,6	0,80	0,40	0,20
		180	MS30	445	368	280	31,8	6,6	1,3	0,60	0,30	0,15
		120	MS30	395	320	239	12,6	2,5	0,5	0,40	0,20	0,10
30°	12 ²⁾	240	MS0	360	290	230	63,7	12,8	2,5	0,80	0,40	0,20

¹⁾ Parallel gears with stop numbers 6, 8 and 10 are designed as a double indexer, i.e. with each full rotation of the drive shaft, two indexes occur in the output.

²⁾ Parallel gears with 12 stops are designed as a four step indexer, i.e. with each full rotation of the drive shaft, four indexes occur in the output.

³⁾ The additional load occurring with chains and belts due to friction is not taken into consideration here and must be calculated separately.

Technical Specifications

Main Dimensions

Shaft distance [mm]	130
Weight without drive [kg]	45
Switching angle [°]	see Load Table (other switching angles upon request)
Numbers of stops	1, 2, 3, 4, 5, 6, 8, 10, 12 (other numbers of stops upon request)
Rotating Direction	right, left, oscillating

Capacities

Max. Output torque	see Load Table
Input Shaft	
Load rating dynamic [kN]	51
Load rating static [kN]	39
Output shaft	
Load rating dynamic [kN]	51
Load rating static [kN]	39

Standard drive (optional)

Motor	SEW oder Kobold
Worm Gear	FRS85
Frame Size	IEC90
Voltage [V]	230/400
Performance [kW]	1,1-1,5

XP165

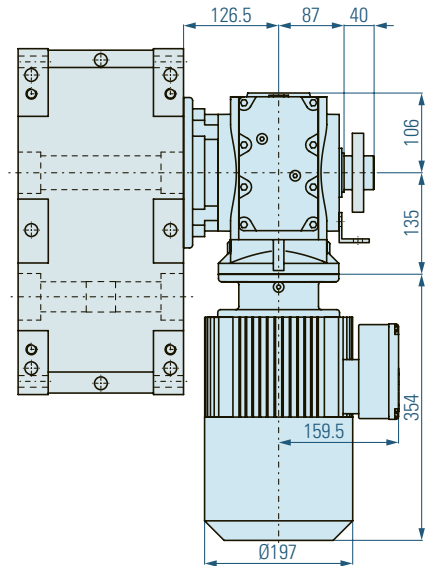
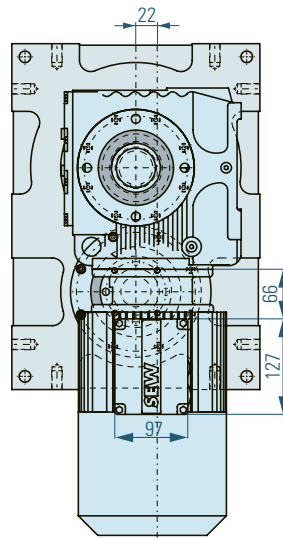
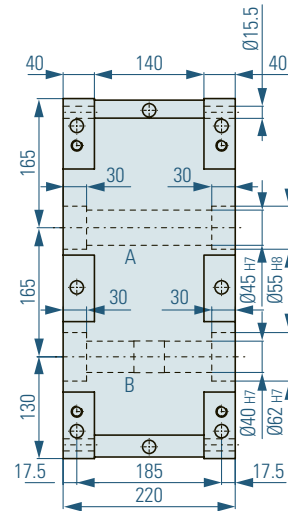
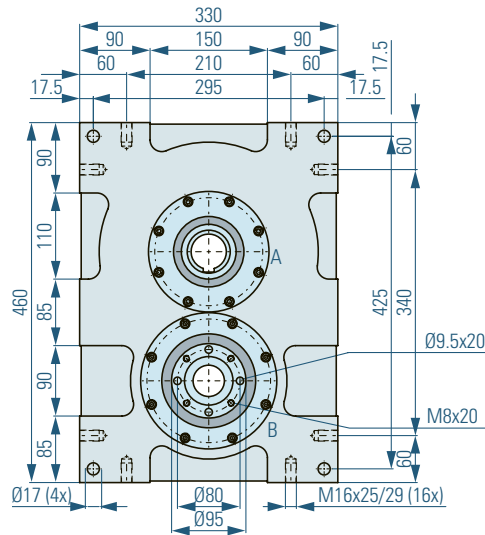

Dimensions

The measurements shown here illustrate the standard version. We will gladly customize the housing and the two shafts to suit your needs. The drive shaft as well as the output shaft is available as

double sided shafts with and without feather gear groove. If you would like to add additional boreholes into the housing yourself, please contact us for possible drilling depths.

- ⚠ Warning! Never drill through the housing.
- ⚠ Warning! Depending on the drive size used, the dimensions of the engine and drive may change.

A = Drive Shaft B = Output Shaft

Load Table XP165

Angle on Output Shaft [°]	Number of Stops n	Switching Angle α [°]	Acceleration Form MS	Engine Torque M_{AB} [Nm]			Moment of Inertia J [kgm ²]			Index Time t_s [s]		
				n=50	n=100	n=200	n=50	n=100	n=200	n=50	n=100	n=200
360°	1	330	MS30	920	760	615	17,7	3,7	0,7	1,10	0,55	0,28
		300	MS50	890	735	580	17,7	3,7	0,7	1,00	0,50	0,25
180°	2	270	MS0	930	840	680	29,9	6,8	1,4	0,90	0,45	0,23
		210	MS30	805	780	630	18,2	4,4	0,9	0,70	0,35	0,18
		150	MS50	790	740	600	6,3	1,5	0,3	0,50	0,25	0,13
120°	3	270	MS0	950	920	680	53,2	12,9	2,4	0,90	0,45	0,23
		210	MS30	840	810	590	24,5	5,9	1,1	0,70	0,35	0,18
		150	MS30	820	790	570	12,2	2,9	0,5	0,50	0,25	0,13
		120	MS30	805	770	540	7,7	1,8	0,3	0,40	0,20	0,10
90°	4	270	MS0	950	920	680	70,9	17,2	3,2	0,90	0,45	0,23
		210	MS0	840	810	590	37,9	9,1	1,7	0,70	0,35	0,18
		150	MS30	820	790	570	16,3	3,9	0,7	0,50	0,25	0,13
		90	MS30	805	770	540	5,8	1,4	0,2	0,30	0,15	0,08
72°	5	270	MS0	950	920	680	88,6	21,5	4,0	0,90	0,45	0,23
		210	MS0	840	810	590	47,4	11,4	2,1	0,70	0,35	0,18
		150	MS30	820	790	570	20,4	4,9	0,9	0,50	0,25	0,13
		90	MS30	805	770	540	7,2	1,7	0,3	0,30	0,15	0,08
60°	6 ¹⁾	270	MS0	930	920	890	104,1	25,7	6,2	0,90	0,45	0,23
		240	MS0	910	900	870	80,5	19,9	4,8	0,80	0,40	0,20
		180	MS30	890	880	850	38,2	9,4	2,3	0,60	0,30	0,15
		120	MS30	860	840	820	16,4	4,0	1,0	0,40	0,20	0,10
45°	8 ¹⁾	270	MS0	790	770	750	117,9	28,7	7,0	0,90	0,45	0,23
		240	MS0	770	750	730	90,8	22,1	5,4	0,80	0,40	0,20
		180	MS30	760	740	710	43,5	10,6	2,5	0,60	0,30	0,15
		120	MS30	750	730	720	19,1	4,6	1,1	0,40	0,20	0,10
36°	10 ¹⁾	270	MS0	790	770	750	147,4	35,9	8,7	0,90	0,45	0,23
		240	MS0	770	750	730	113,5	27,6	6,7	0,80	0,40	0,20
		180	MS30	760	740	710	54,4	13,2	3,2	0,60	0,30	0,15
		120	MS30	750	730	720	23,8	5,8	1,4	0,40	0,20	0,10
30°	12 ²⁾	240	MS0	730	720	700	129,1	31,8	7,7	0,80	0,40	0,20

¹⁾ Parallel gears with stop numbers 6, 8 and 10 are designed as a double indexer, i.e. with each full rotation of the drive shaft, two indexes occur in the output.

²⁾ Parallel gears with 12 stops are designed as a four step indexer, i.e. with each full rotation of the drive shaft, four indexes occur in the output.

³⁾ The additional load occurring with chains and belts due to friction is not taken into consideration here and must be calculated separately.

Technical Specifications

Main Dimensions

Shaft distance [mm]	165
Weight without drive [kg]	120
Switching angle [°]	see Load Table (other switching angles upon request)
Numbers of stops	1, 2, 3, 4, 5, 6, 8, 10, 12 (other numbers of stops upon request)
Rotating Direction	right, left, oscillating

Capacities

Max. Output torque	see Load Table
Input Shaft	
Load rating dynamic [kN]	116
Load rating static [kN]	153
Output shaft	
Load rating dynamic [kN]	168
Load rating static [kN]	270

Standard drive (optional)

Motor	SEW oder Kobold
Worm Gear	SAF67
Frame Size	IEC100
Voltage [V]	230/400
Performance [kW]	2,2-3,0

XP200

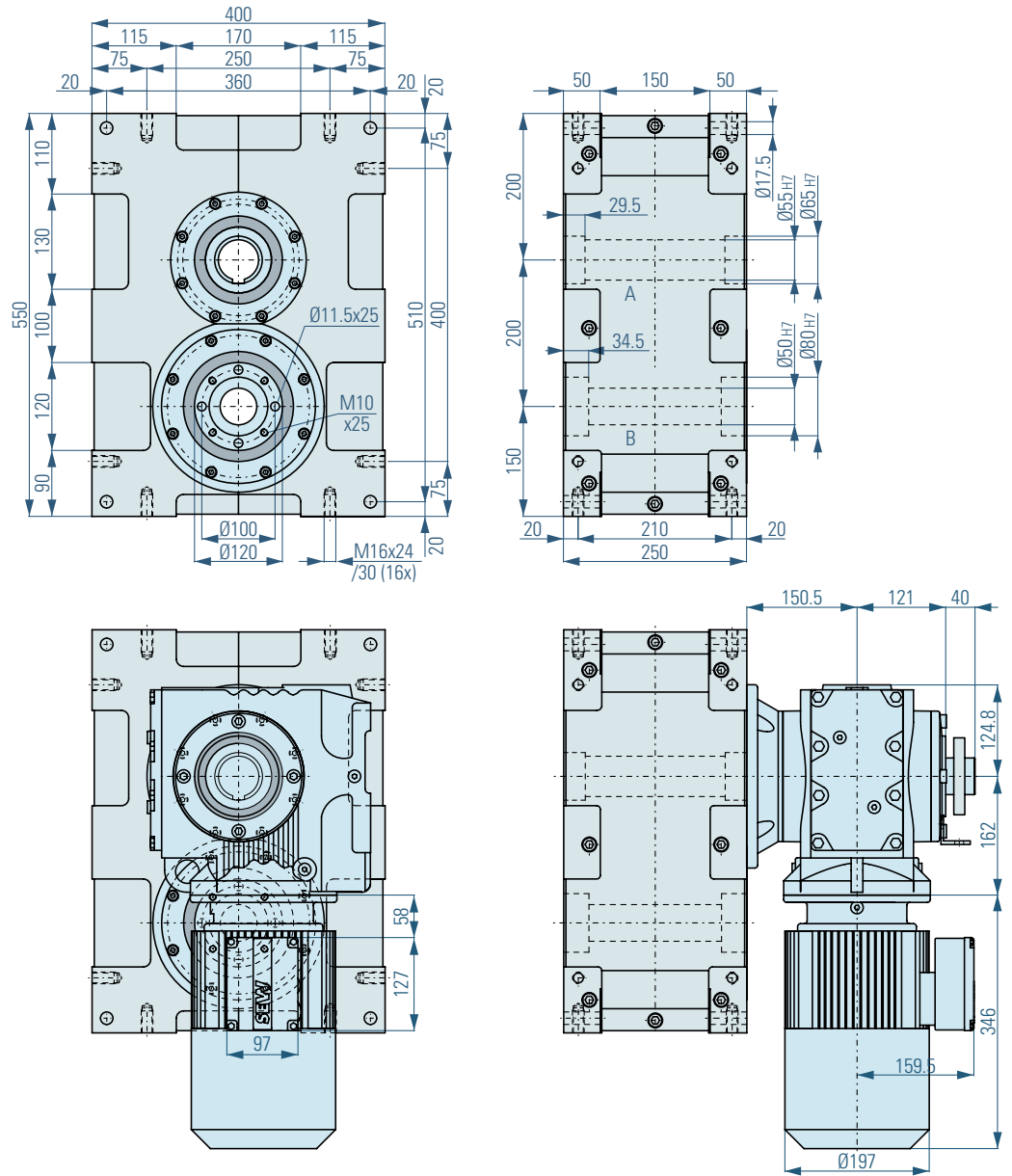

Dimensions

The measurements shown here illustrate the standard version. We will gladly customize the housing and the two shafts to suit your needs. The drive shaft as well as the output shaft is available as

double sided shafts with and without feather gear groove. If you would like to add additional boreholes into the housing yourself, please contact us for possible drilling depths.

- ⚠ Warning! Never drill through the housing.
- ⚠ Warning! Depending on the drive size used, the dimensions of the engine and drive may change.

A = Drive Shaft B = Output Shaft

Load Table XP200

Angle on Output Shaft [°]	Number of Stops n	Switching Angle α [°]	Acceleration Form MS	Engine Torque M_{AB} [Nm]			Moment of Inertia J [kgm ²]			Index Time t_s [s]		
				n=50	n=100	n=200	n=50	n=100	n=200	n=50	n=100	n=200
360°	1	330	MS30	1530	1255	1004	29	6,0	1,2	1,10	0,55	0,28
		300	MS50	1450	1190	950	29	5,9	1,2	1,00	0,50	0,25
180°	2	270	MS0	1590	1305	1040	51	10,5	2,1	0,90	0,45	0,23
		210	MS30	1460	1200	960	33	6,8	1,4	0,70	0,35	0,18
		150	MS50	1390	1140	910	11	2,3	0,5	0,50	0,25	0,13
120°	3	270	MS0	1680	1380	1100	94	19,3	3,8	0,90	0,45	0,23
		210	MS30	1590	1305	1045	46	9,5	1,9	0,70	0,35	0,18
		150	MS30	1490	1220	980	22	4,5	0,9	0,50	0,25	0,13
		120	MS30	1480	1215	970	14	2,9	0,6	0,40	0,20	0,10
90°	4	270	MS0	1470	1205	965	110	22,5	4,5	0,90	0,45	0,23
		210	MS0	1440	1181	945	65	13,3	2,7	0,70	0,35	0,18
		150	MS30	1390	1140	910	28	5,7	1,1	0,50	0,25	0,13
		90	MS30	1370	1120	900	10	2,0	0,4	0,30	0,15	0,08
72°	5	270	MS0	1470	1205	965	137	28,1	5,6	0,90	0,45	0,23
		210	MS0	1440	1180	945	81	16,6	3,3	0,70	0,35	0,18
		150	MS30	1390	1140	910	35	7,1	1,4	0,50	0,25	0,13
		90	MS30	1370	1125	900	12	2,5	0,5	0,30	0,15	0,08
60°	6 ¹⁾	270	MS0	1520	1430	1340	170	40,0	9,4	0,90	0,45	0,23
		240	MS0	1490	1220	980	132	27,0	5,4	0,80	0,40	0,20
		180	MS30	1460	1370	1270	63	14,7	3,4	0,60	0,30	0,15
		120	MS30	1420	1335	1240	27	6,4	1,5	0,40	0,20	0,10
45°	8 ¹⁾	270	MS0	1290	1210	1140	193	45,2	10,6	0,90	0,45	0,23
		240	MS0	1270	1195	1120	150	35,2	8,3	0,80	0,40	0,20
		180	MS30	1260	1180	1110	72	16,9	4,0	0,60	0,30	0,15
		120	MS30	1240	1166	1100	32	7,4	1,7	0,40	0,20	0,10
36°	10 ¹⁾	270	MS0	1290	1210	1140	241	56,4	13,3	0,90	0,45	0,23
		240	MS0	1270	1195	1120	187	44,0	10,3	0,80	0,40	0,20
		180	MS30	1260	1180	1110	90	21,1	5,0	0,60	0,30	0,15
		120	MS30	1240	1166	1100	39	9,3	2,2	0,40	0,20	0,10
30°	12 ²⁾	240	MS0	1190	1140	1090	211	50,4	12,1	0,80	0,40	0,20

¹⁾ Parallel gears with stop numbers 6, 8 and 10 are designed as a double indexer, i.e. with each full rotation of the drive shaft, two indexes occur in the output.

²⁾ Parallel gears with 12 stops are designed as a four step indexer, i.e. with each full rotation of the drive shaft, four indexes occur in the output.

³⁾ The additional load occurring with chains and belts due to friction is not taken into consideration here and must be calculated separately.

Technical Specifications

Main Dimensions

Shaft distance [mm]	200
Weight without drive [kg]	220
Switching angle [°] (other switching angles upon request)	see Load Table
Numbers of stops (other numbers of stops upon request)	1, 2, 3, 4, 5, 6, 8, 10, 12
Rotating Direction	right, left, oscillating

Capacities

Max. Output torque	see Load Table
Input Shaft	
Load rating dynamic [kN]	168
Load rating static [kN]	270
Output shaft	
Load rating dynamic [kN]	242
Load rating static [kN]	415

Standard drive (optional)

Motor	SEW oder Kobold
Worm Gear	SAF77
Frame Size	IEC100
Voltage [V]	230/400
Performance [kW]	2,2-3,0

XP250

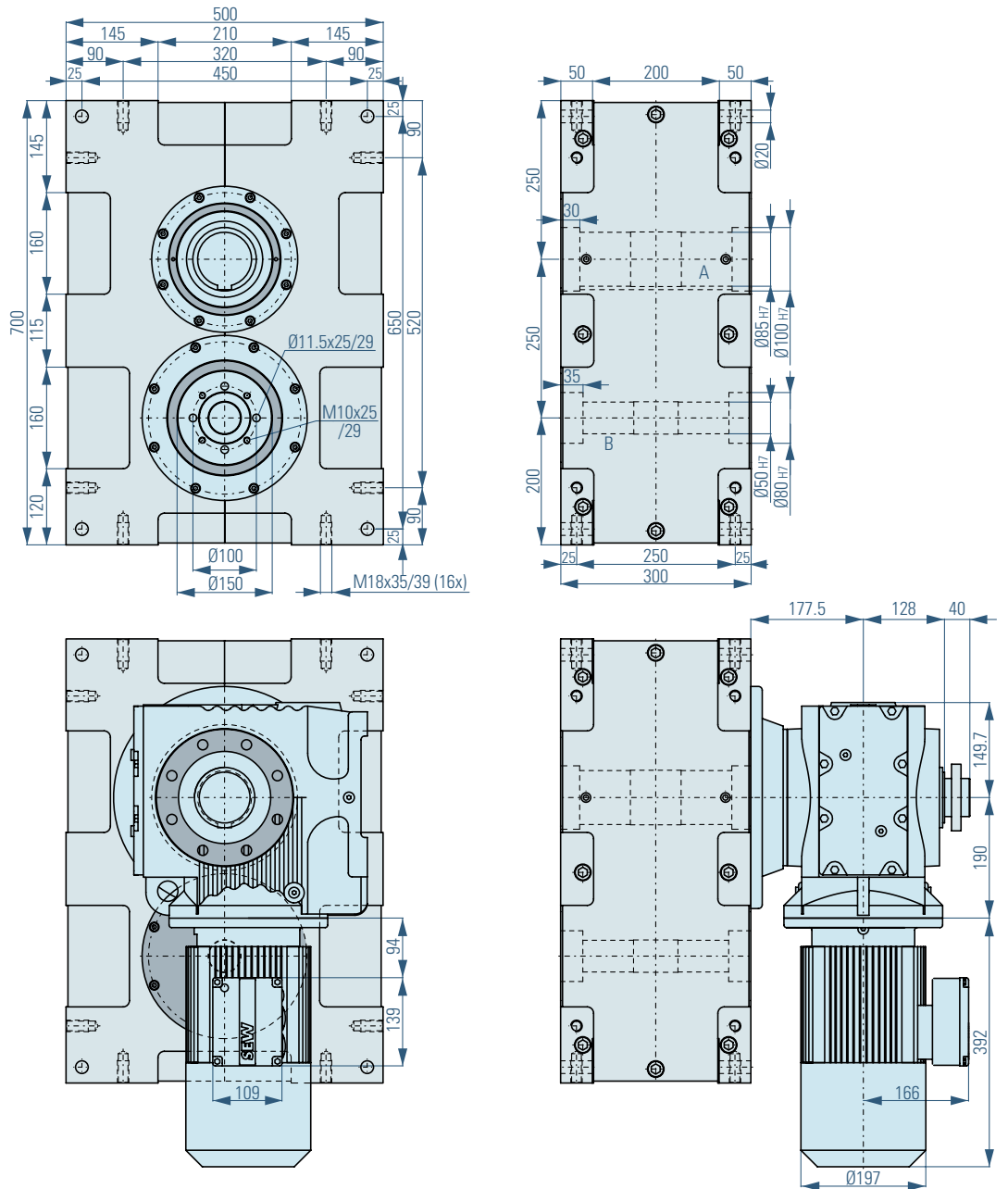

Dimensions

The measurements shown here illustrate the standard version. We will gladly customize the housing and the two shafts to suit your needs. The drive shaft as well as the output shaft is available as

double sided shafts with and without feather gear groove. If you would like to add additional boreholes into the housing yourself, please contact us for possible drilling depths.

- ⚠ Warning! Never drill through the housing.
- ⚠ Warning! Depending on the drive size used, the dimensions of the engine and drive may change.

A = Drive Shaft B = Output Shaft

Load Table XP250

Angle on Output Shaft [°]	Number of Stops n	Switching Angle α [°]	Acceleration Form MS	Engine Torque M_{AB} [Nm]			Moment of Inertia J [kgm ²]			Index Time t_s [s]		
				n=50	n=100	n=200	n=50	n=100	n=200	n=50	n=100	n=200
360°	1	330	MS30	2750	2255	1827	53	10,9	2,2	1,10	0,55	0,28
		300	MS50	2680	2020	1635	53	10,0	2,0	1,00	0,50	0,25
180°	2	270	MS0	2810	2300	1860	90	18,5	3,7	0,90	0,45	0,23
		210	MS30	2480	2035	1650	56	11,5	2,3	0,70	0,35	0,18
		150	MS50	2430	1990	1610	19	4,0	0,8	0,50	0,25	0,13
120°	3	270	MS0	2870	2350	1905	161	32,9	6,7	0,90	0,45	0,23
		210	MS30	2690	2200	1780	79	16,1	3,3	0,70	0,35	0,18
		150	MS30	2510	2060	1665	37	7,7	1,6	0,50	0,25	0,13
		120	MS30	2490	2040	1655	24	4,9	1,0	0,40	0,20	0,10
90°	4	270	MS0	2690	2205	1790	201	41,1	8,3	0,90	0,45	0,23
		210	MS0	2670	2189	1773	121	24,7	5,0	0,70	0,35	0,18
		150	MS30	2610	2140	1734	52	10,6	2,2	0,50	0,25	0,13
		90	MS30	2570	2110	1710	18	3,8	0,8	0,30	0,15	0,08
72°	5	270	MS0	2690	2205	1790	251	51,4	10,4	0,90	0,45	0,23
		210	MS0	2670	2189	1773	151	30,9	6,3	0,70	0,35	0,18
		150	MS30	2610	2140	1734	65	13,3	2,7	0,50	0,25	0,13
		90	MS30	2570	2110	1710	23	4,7	1,0	0,30	0,15	0,08
60°	6 ¹⁾	270	MS0	2810	2700	2570	315	75,6	18,0	0,90	0,45	0,23
		240	MS0	2730	2630	2510	241	58,2	13,9	0,80	0,40	0,20
		180	MS30	2590	2490	2310	111	26,7	6,2	0,60	0,30	0,15
		120	MS30	2540	2410	2260	48	11,5	2,7	0,40	0,20	0,10
45°	8 ¹⁾	270	MS0	2530	2400	2290	378	89,6	21,4	0,90	0,45	0,23
		240	MS0	2470	2370	2210	291	69,9	16,3	0,80	0,40	0,20
		180	MS30	2410	2300	2180	138	32,9	7,8	0,60	0,30	0,15
		120	MS30	2380	2270	2150	61	14,4	3,4	0,40	0,20	0,10
36°	10 ¹⁾	270	MS0	2530	2400	2290	472	112,0	26,7	0,90	0,45	0,23
		240	MS0	2470	2370	2210	364	87,4	20,4	0,80	0,40	0,20
		180	MS30	2410	2300	2180	172	41,1	9,7	0,60	0,30	0,15
		120	MS30	2380	2270	2150	76	18,0	4,3	0,40	0,20	0,10
30°	12 ²⁾	240	MS0	2250	2120	1990	398	93,8	22,0	0,80	0,40	0,20

¹⁾ Parallel gears with stop numbers 6, 8 and 10 are designed as a double indexer, i.e. with each full rotation of the drive shaft, two indexes occur in the output.

²⁾ Parallel gears with 12 stops are designed as a four step indexer, i.e. with each full rotation of the drive shaft, four indexes occur in the output.

³⁾ The additional load occurring with chains and belts due to friction is not taken into consideration here and must be calculated separately.

Technical Specifications

Main Dimensions

Shaft distance [mm]	250
Weight without drive [kg]	350
Switching angle [°] (other switching angles upon request)	see Load Table
Numbers of stops (other numbers of stops upon request)	1, 2, 3, 4, 5, 6, 8, 10, 12
Rotating Direction	right, left, oscillating

Capacities

Max. Output torque	see Load Table
Input Shaft	
Load rating dynamic [kN]	242
Load rating static [kN]	415
Output shaft	
Load rating dynamic [kN]	365
Load rating static [kN]	655

Standard drive (optional)

Motor	SEW oder Kobold
Worm Gear	SAF87
Frame Size	IEC100
Voltage [V]	230/400
Performance [kW]	2,2-3,0

TP040

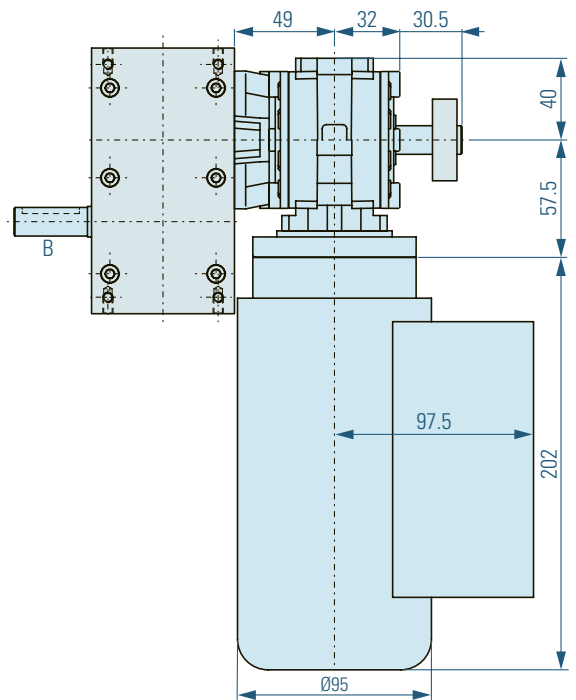
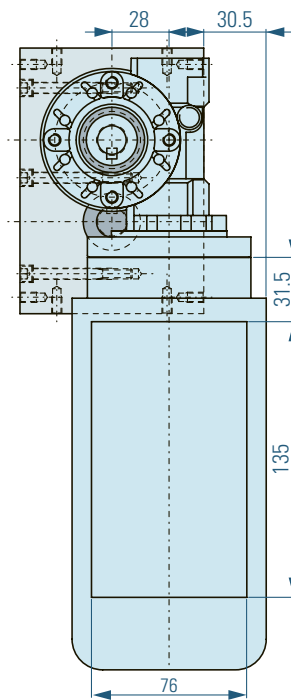
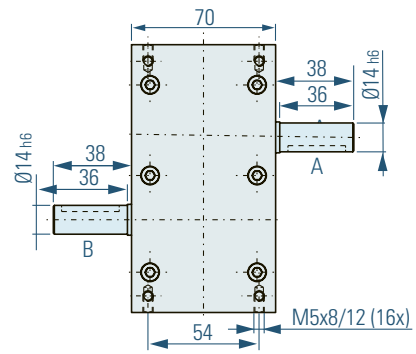
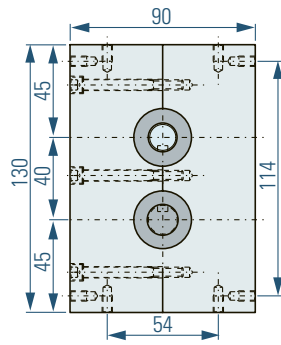

Dimensions

The measurements shown here illustrate the standard version. We will gladly customize the housing and the two shafts to suit your needs. The drive shaft as well as the output shaft is available as

double sided shafts with and without feather gear groove. If you would like to add additional boreholes into the housing yourself, please contact us for possible drilling depths.

- ⚠ Warning! Never drill through the housing.
- ⚠ Warning! Depending on the drive size used, the dimensions of the engine and drive may change.

A = Drive Shaft B = Output Shaft

Load Table TP040

Angle on Output Shaft [°]	Number of Stops n	Switching Angle α [°]	Acceleration Form MS	Engine Torque M_{AB} [Nm]			Moment of Inertia J [kgm ²]			Index Time t_s [s]		
				n=50	n=100	n=200	n=50	n=100	n=200	n=50	n=100	n=200
360°	1	330	MS30	29	25	21	0,56	0,12	0,03	1,10	0,55	0,28
		300	MS50	28	24	20	0,56	0,12	0,02	1,00	0,50	0,25
180°	2	270	MS0	32	27	24	1,03	0,22	0,05	0,90	0,45	0,23
		210	MS30	26	24	21	0,59	0,14	0,03	0,70	0,35	0,18
		150	MS50	25	23	20	0,20	0,05	0,01	0,50	0,25	0,13
120°	3	270	MS0	39	33	26	2,18	0,46	0,09	0,90	0,45	0,23
		210	MS30	39	33	26	1,14	0,24	0,05	0,70	0,35	0,18
		150	MS30	33	27	23	0,49	0,10	0,02	0,50	0,25	0,13
		120	MS30	30	25	20	0,29	0,06	0,01	0,40	0,20	0,10
90°	4	270	MS0	36	30	24	2,69	0,56	0,11	0,90	0,45	0,23
		210	MS0	36	30	24	1,63	0,34	0,07	0,70	0,35	0,18
		150	MS30	35	29	23	0,70	0,14	0,03	0,50	0,25	0,13
		90	MS30	32	28	21	0,23	0,05	0,01	0,30	0,15	0,08
72°	5	270	MS0	36	30	24	3,36	0,70	0,14	0,90	0,45	0,23
		210	MS0	36	30	24	2,03	0,42	0,08	0,70	0,35	0,18
		150	MS30	35	29	23	0,87	0,18	0,04	0,50	0,25	0,13
		90	MS30	32	28	21	0,29	0,06	0,01	0,30	0,15	0,08
60°	6 ¹⁾	270	MS0	42	34	28	4,70	0,95	0,20	0,90	0,45	0,23
		240	MS0	42	34	28	3,72	0,75	0,15	0,80	0,40	0,20
		180	MS30	40	32	25	1,72	0,34	0,07	0,60	0,30	0,15
		120	MS30	36	29	22	0,69	0,14	0,03	0,40	0,20	0,10
45°	8 ¹⁾	270	MS0	42	34	28	6,27	1,27	0,26	0,90	0,45	0,23
		240	MS0	42	34	28	4,95	1,00	0,21	0,80	0,40	0,20
		180	MS30	40	32	25	2,29	0,46	0,09	0,60	0,30	0,15
		120	MS30	36	29	22	0,92	0,18	0,03	0,40	0,20	0,10
36	10 ¹⁾	270	MS0	42	34	28	7,84	1,59	0,33	0,90	0,45	0,23
		240	MS0	42	34	28	6,19	1,25	0,26	0,80	0,40	0,20
		180	MS30	40	32	25	2,86	0,57	0,11	0,60	0,30	0,15
		120	MS30	36	29	22	1,14	0,23	0,04	0,40	0,20	0,10

¹⁾ Parallel gears with stop numbers 6, 8 and 10 are designed as a double indexer, i.e. with each full rotation of the drive shaft, two indexes occur in the output.

²⁾ Parallel gears with 12 stops are designed as a four step indexer, i.e. with each full rotation of the drive shaft, four indexes occur in the output.

³⁾ The additional load occurring with chains and belts due to friction is not taken into consideration here and must be calculated separately.

Technical Specifications

Main Dimensions

Shaft distance [mm]	40
Weight without drive [kg]	2
Switching angle [°] (other switching angles upon request)	see Load Table
Numbers of stops (other numbers of stops upon request)	1, 2, 3, 4, 5, 6, 8, 10
Rotating Direction	right, left, oscillating

Capacities

Max. Output torque	see Load Table
Input Shaft	
Load rating dynamic [kN]	4,36
Load rating static [kN]	2,24
Output shaft	
Load rating dynamic [kN]	4,36
Load rating static [kN]	2,24

Standard drive (optional)

Motor	SEW oder Kobold
Worm Gear	FRS28
Frame Size	IEC56
Voltage [V]	230/400
Performance [kW]	0,06-0,09

TP063

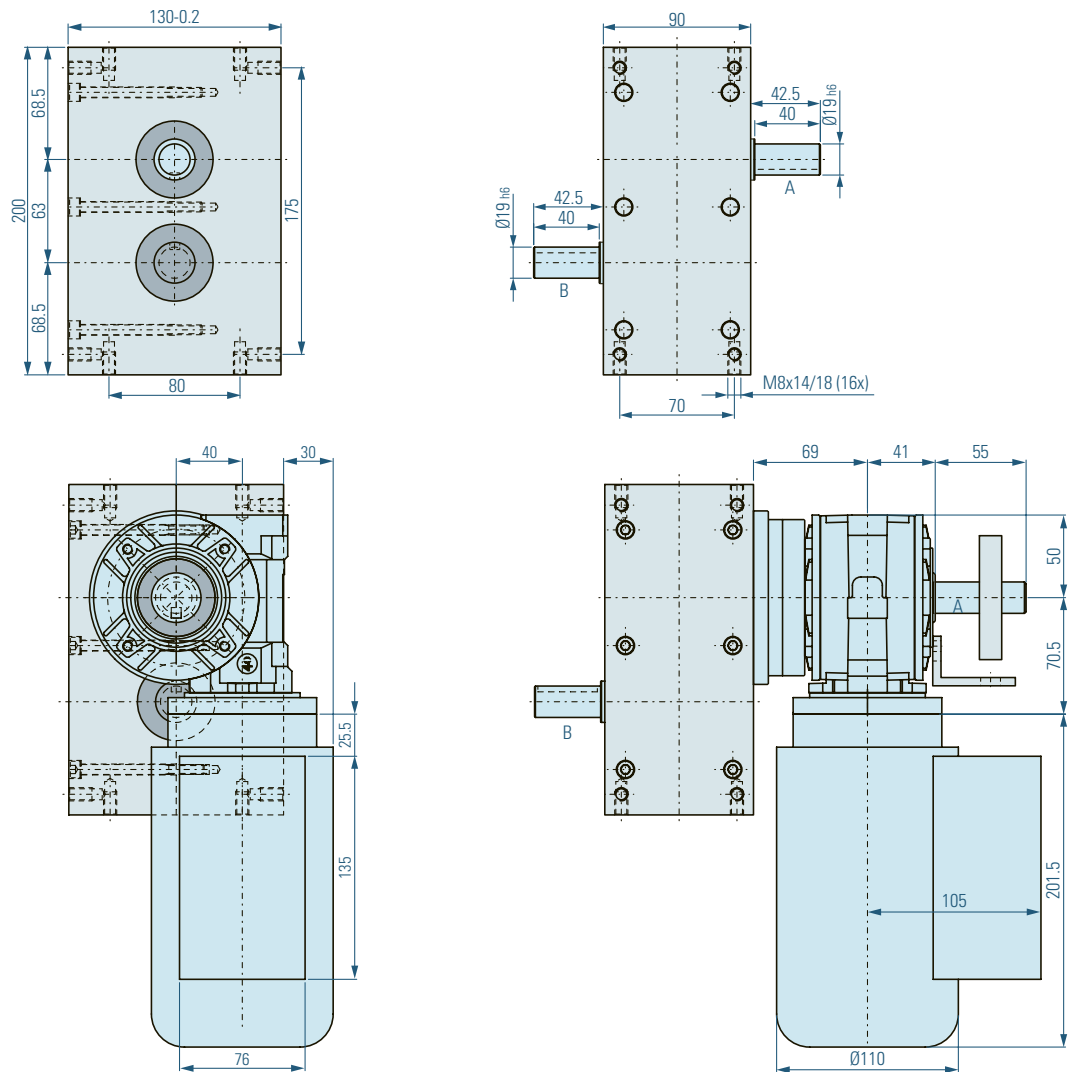

Dimensions

The measurements shown here illustrate the standard version. We will gladly customize the housing and the two shafts to suit your needs. The drive shaft as well as the output shaft is available as

double sided shafts with and without feather gear groove. If you would like to add additional boreholes into the housing yourself, please contact us for possible drilling depths.

- ⚠ Warning! Never drill through the housing.
- ⚠ Warning! Depending on the drive size used, the dimensions of the engine and drive may change.

A = Drive Shaft B = Output Shaft

Load Table TP063

Angle on Output Shaft [°]	Number of Stops n	Switching Angle α [°]	Acceleration Form MS	Engine Torque M_{AB} [Nm]			Moment of Inertia J [kgm ²]			Index Time t_s [s]		
				n=50	n=100	n=200	n=50	n=100	n=200	n=50	n=100	n=200
360°	1	330	MS30	52	43	36	1,0	0,2	0,04	1,10	0,55	0,28
		300	MS50	48	39	30	1,0	0,2	0,04	1,00	0,50	0,25
180°	2	270	MS0	58	51	43	1,9	0,4	0,09	0,90	0,45	0,23
		210	MS30	48	46	41	1,1	0,3	0,06	0,70	0,35	0,18
		150	MS50	42	40	39	0,3	0,1	0,02	0,50	0,25	0,13
120°	3	270	MS0	74	68	59	4,1	1,0	0,21	0,90	0,45	0,23
		210	MS30	73	67	57	2,1	0,5	0,10	0,70	0,35	0,18
		150	MS30	61	53	46	0,9	0,2	0,04	0,50	0,25	0,13
		120	MS30	60	52	43	0,6	0,1	0,03	0,40	0,20	0,10
90°	4	270	MS0	68	61	53	5,1	1,1	0,25	0,90	0,45	0,23
		210	MS0	66	59	51	3,0	0,7	0,14	0,70	0,35	0,18
		150	MS30	64	57	49	1,3	0,3	0,06	0,50	0,25	0,13
		90	MS30	64	57	49	0,5	0,1	0,02	0,30	0,15	0,08
72°	5	270	MS0	68	61	53	6,3	1,4	0,31	0,90	0,45	0,23
		210	MS0	66	59	51	3,7	0,8	0,18	0,70	0,35	0,18
		150	MS30	64	57	49	1,6	0,4	0,08	0,50	0,25	0,13
		90	MS30	64	57	49	0,6	0,1	0,03	0,30	0,15	0,08
60°	6 ¹⁾	270	MS0	86	71	56	9,6	2,0	0,39	0,90	0,45	0,23
		240	MS0	83	69	54	7,3	1,5	0,30	0,80	0,40	0,20
		180	MS30	79	65	51	3,4	0,7	0,14	0,60	0,30	0,15
		120	MS30	75	61	46	1,4	0,3	0,05	0,40	0,20	0,10
45°	8 ¹⁾	270	MS0	86	71	56	12,8	2,6	0,52	0,90	0,45	0,23
		240	MS0	83	69	54	9,8	2,0	0,40	0,80	0,40	0,20
		180	MS30	79	65	51	4,5	0,9	0,18	0,60	0,30	0,15
		120	MS30	75	61	46	1,9	0,4	0,07	0,40	0,20	0,10
36°	10 ¹⁾	270	MS0	86	71	56	16,0	3,3	0,65	0,90	0,45	0,23
		240	MS0	83	69	54	12,2	2,5	0,50	0,80	0,40	0,20
		180	MS30	79	65	51	5,7	1,2	0,23	0,60	0,30	0,15
		120	MS30	75	61	46	2,4	0,5	0,09	0,40	0,20	0,10
30°	12 ²⁾	240	MS0	62	51	39	11,0	2,3	0,43	0,80	0,40	0,20

¹⁾ Parallel gears with stop numbers 6, 8 and 10 are designed as a double indexer, i.e. with each full rotation of the drive shaft, two indexes occur in the output.

²⁾ Parallel gears with 12 stops are designed as a four step indexer, i.e. with each full rotation of the drive shaft, four indexes occur in the output.

³⁾ The additional load occurring with chains and belts due to friction is not taken into consideration here and must be calculated separately.

Technical Specifications

Main Dimensions

Shaft distance [mm]	63
Weight without drive [kg]	8
Switching angle [°] (other switching angles upon request)	see Load Table
Numbers of stops (other numbers of stops upon request)	1, 2, 3, 4, 5, 6, 8, 10, 12
Rotating Direction	right, left, oscillating

Capacities

Max. Output torque	see Load Table
Input Shaft	
Load rating dynamic [kN]	11,9
Load rating static [kN]	6,55
Output shaft	
Load rating dynamic [kN]	8,06
Load rating static [kN]	4,75

Standard drive (optional)

Motor	SEW oder Kobold
Worm Gear	FRS40
Frame Size	IEC63
Voltage [V]	230/400
Performance [kW]	0,12-0,25

TP080

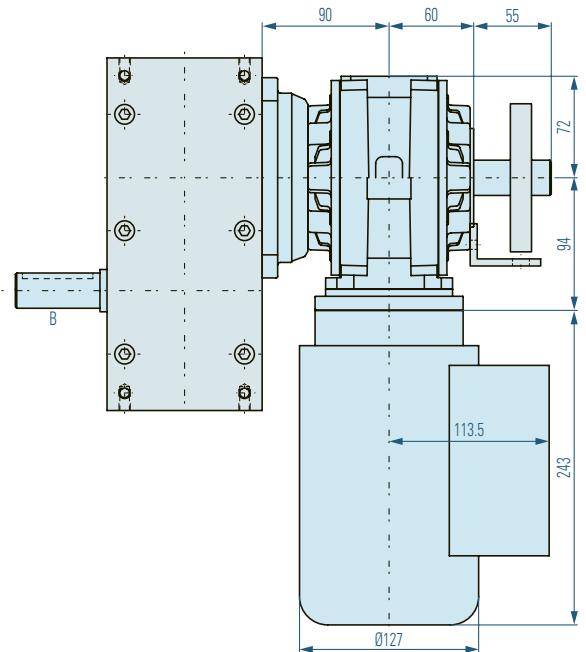
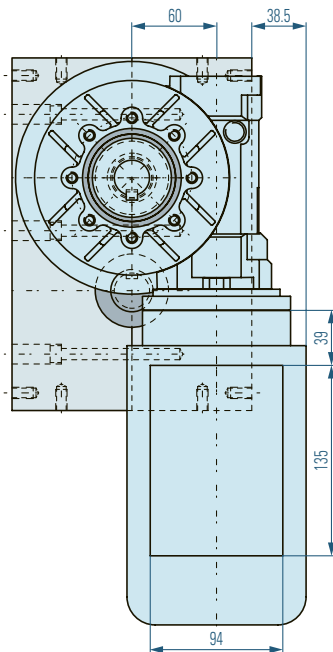
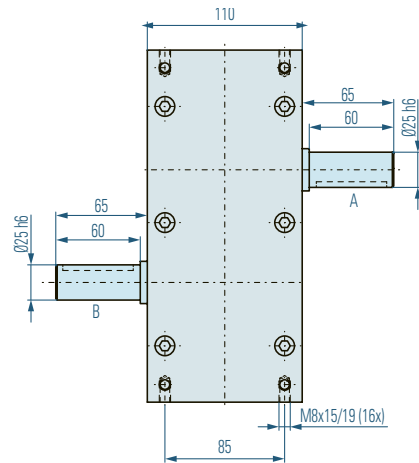
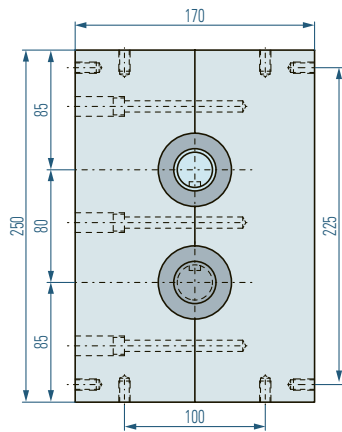

Dimensions

The measurements shown here illustrate the standard version. We will gladly customize the housing and the two shafts to suit your needs. The drive shaft as well as the output shaft is available as

double sided shafts with and without feather gear groove. If you would like to add additional boreholes into the housing yourself, please contact us for possible drilling depths.

⚠ Warning! Never drill through the housing.

⚠ Warning! Depending on the drive size used, the dimensions of the engine and drive may change.

A = Drive Shaft B = Output Shaft

Load Table TP080

Angle on Output Shaft [°]	Number of Stops n	Switching Angle α [°]	Acceleration Form MS	Engine Torque M_{AB} [Nm]			Moment of Inertia J [kgm ²]			Index Time t_s [s]		
				n=50	n=100	n=200	n=50	n=100	n=200	n=50	n=100	n=200
360°	1	330	MS30	124	102	81	2,4	0,5	0,10	1,10	0,55	0,28
		300	MS50	123	101	79	2,4	0,5	0,10	1,00	0,50	0,25
180°	2	270	MS0	132	107	93	4,2	0,9	0,19	0,90	0,45	0,23
		210	MS30	131	107	93	3,0	0,6	0,13	0,70	0,35	0,18
		150	MS50	103	96	89	0,8	0,2	0,04	0,50	0,25	0,13
120°	3	270	MS0	159	137	112	8,9	1,9	0,39	0,90	0,45	0,23
		210	MS30	152	129	101	4,4	0,9	0,18	0,70	0,35	0,18
		150	MS30	127	103	83	1,9	0,4	0,08	0,50	0,25	0,13
		120	MS30	119	97	78	1,1	0,2	0,05	0,40	0,20	0,10
90°	4	270	MS0	157	132	109	11,7	2,5	0,51	0,90	0,45	0,23
		210	MS0	151	126	96	6,8	1,4	0,27	0,70	0,35	0,18
		150	MS30	138	112	88	2,7	0,6	0,11	0,50	0,25	0,13
		90	MS30	118	92	76	0,8	0,2	0,03	0,30	0,15	0,08
72°	5	270	MS0	157	132	109	14,6	3,1	0,64	0,90	0,45	0,23
		210	MS0	151	126	96	8,5	1,8	0,34	0,70	0,35	0,18
		150	MS30	138	112	88	3,4	0,7	0,14	0,50	0,25	0,13
		90	MS30	118	92	76	1,1	0,2	0,04	0,30	0,15	0,08
60°	6 ¹⁾	270	MS0	186	149	124	20,8	4,2	0,87	0,90	0,45	0,23
		240	MS0	174	146	120	15,4	3,2	0,66	0,80	0,40	0,20
		180	MS30	160	122	96	6,9	1,3	0,26	0,60	0,30	0,15
		120	MS30	132	105	81	2,5	0,5	0,10	0,40	0,20	0,10
45°	8 ¹⁾	270	MS0	186	149	124	27,8	5,6	1,16	0,90	0,45	0,23
		240	MS0	174	146	120	20,5	4,3	0,88	0,80	0,40	0,20
		180	MS30	160	122	96	9,2	1,7	0,34	0,60	0,30	0,15
		120	MS30	132	105	81	3,4	0,7	0,13	0,40	0,20	0,10
36°	10 ¹⁾	270	MS0	186	149	124	34,7	7,0	1,45	0,90	0,45	0,23
		240	MS0	174	146	120	25,7	5,4	1,11	0,80	0,40	0,20
		180	MS30	160	122	96	11,4	2,2	0,43	0,60	0,30	0,15
		120	MS30	132	105	81	4,2	0,8	0,16	0,40	0,20	0,10
30°	12 ²⁾	240	MS0	110	95	76	19,5	4,2	0,84	0,80	0,40	0,20

¹⁾ Parallel gears with stop numbers 6, 8 and 10 are designed as a double indexer, i.e. with each full rotation of the drive shaft, two indexes occur in the output.

²⁾ Parallel gears with 12 stops are designed as a four step indexer, i.e. with each full rotation of the drive shaft, four indexes occur in the output.

³⁾ The additional load occurring with chains and belts due to friction is not taken into consideration here and must be calculated separately.

Technical Specifications

Main Dimensions

Shaft distance [mm]	80
Weight without drive [kg]	16
Switching angle [°]	see Load Table (other switching angles upon request)
Numbers of stops	1, 2, 3, 4, 5, 6, 8, 10, 12 (other numbers of stops upon request)
Rotating Direction	right, left, oscillating

Capacities

Max. Output torque	see Load Table
Input Shaft	
Load rating dynamic [kN]	13,8
Load rating static [kN]	8,3
Output shaft	
Load rating dynamic [kN]	13,8
Load rating static [kN]	8,3

Standard drive (optional)

Motor	SEW oder Kobold
Worm Gear	FRS60
Frame Size	IEC71
Voltage [V]	230/400
Performance [kW]	0,37

TP100

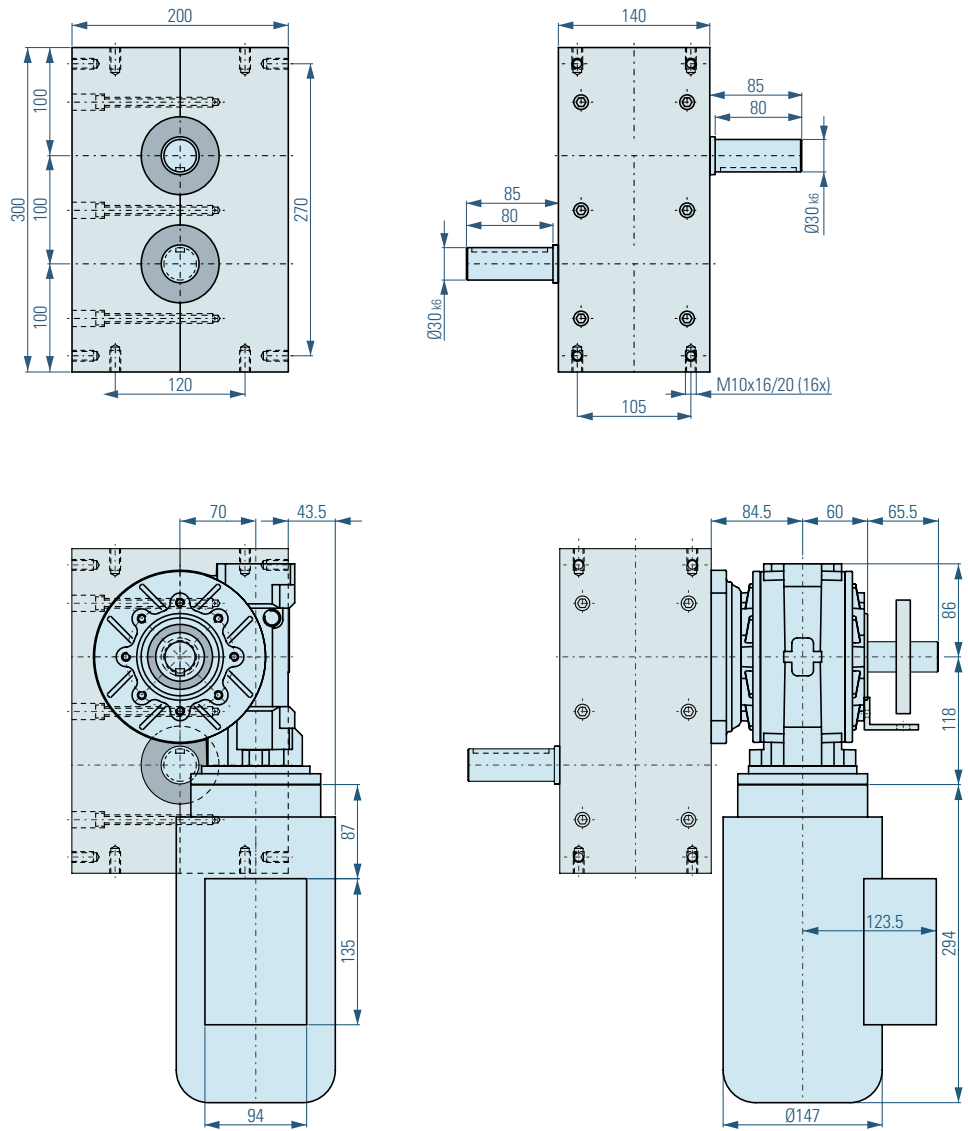

Dimensions

The measurements shown here illustrate the standard version. We will gladly customize the housing and the two shafts to suit your needs. The drive shaft as well as the output shaft is available as

double sided shafts with and without feather gear groove. If you would like to add additional boreholes into the housing yourself, please contact us for possible drilling depths.

- ⚠ Warning! Never drill through the housing.
- ⚠ Warning! Depending on the drive size used, the dimensions of the engine and drive may change.

A = Drive Shaft B = Output Shaft

Load Table TP100

Angle on Output Shaft [°]	Number of Stops n	Switching Angle α [°]	Acceleration Form MS	Engine Torque M_{AB} [Nm]			Moment of Inertia J [kgm ²]			Index Time t_s [s]		
				n=50	n=100	n=200	n=50	n=100	n=200	n=50	n=100	n=200
360°	1	330	MS30	211	171	135	4,1	0,8	0,2	1,10	0,55	0,28
		300	MS50	203	167	129	4,0	0,8	0,2	1,00	0,50	0,25
180°	2	270	MS0	290	259	225	9,3	2,1	0,5	0,90	0,45	0,23
		210	MS30	278	245	216	6,3	1,4	0,3	0,70	0,35	0,18
		150	MS50	248	199	151	2,0	0,4	0,1	0,50	0,25	0,13
120°	3	270	MS0	353	312	272	19,7	4,4	1,0	0,90	0,45	0,23
		210	MS30	342	305	264	10,0	2,2	0,5	0,70	0,35	0,18
		150	MS30	336	299	255	5,0	1,1	0,2	0,50	0,25	0,13
		120	MS30	332	294	250	3,2	0,7	0,1	0,40	0,20	0,10
90°	4	270	MS0	333	291	239	24,9	5,4	1,1	0,90	0,45	0,23
		210	MS0	322	284	233	14,6	3,2	0,7	0,70	0,35	0,18
		150	MS30	311	273	221	6,2	1,4	0,3	0,50	0,25	0,13
		90	MS30	285	263	216	2,0	0,5	0,1	0,30	0,15	0,08
72°	5	270	MS0	333	291	239	31,1	6,8	1,4	0,90	0,45	0,23
		210	MS0	322	284	233	18,2	4,0	0,8	0,70	0,35	0,18
		150	MS30	311	273	221	7,7	1,7	0,3	0,50	0,25	0,13
		90	MS30	285	263	216	2,6	0,6	0,1	0,30	0,15	0,08
60°	6 ¹⁾	270	MS0	382	343	291	42,8	9,6	2,0	0,90	0,45	0,23
		240	MS0	368	331	279	32,6	7,3	1,5	0,80	0,40	0,20
		180	MS30	298	254	197	12,8	2,7	0,5	0,60	0,30	0,15
		120	MS30	275	234	176	5,2	1,1	0,2	0,40	0,20	0,10
45°	8 ¹⁾	270	MS0	382	343	291	57,0	12,8	2,7	0,90	0,45	0,23
		240	MS0	368	331	279	43,4	9,8	2,1	0,80	0,40	0,20
		180	MS30	298	254	197	17,1	3,6	0,7	0,60	0,30	0,15
		120	MS30	275	234	176	7,0	1,5	0,3	0,40	0,20	0,10
36°	10 ¹⁾	270	MS0	382	343	291	71,3	16,0	3,4	0,90	0,45	0,23
		240	MS0	368	331	279	54,3	12,2	2,6	0,80	0,40	0,20
		180	MS30	298	254	197	21,3	4,5	0,9	0,60	0,30	0,15
		120	MS30	275	234	176	8,7	1,9	0,3	0,40	0,20	0,10
30°	12 ²⁾	240	MS0	264	215	166	46,7	9,5	1,8	0,80	0,40	0,20

¹⁾ Parallel gears with stop numbers 6, 8 and 10 are designed as a double indexer, i.e. with each full rotation of the drive shaft, two indexes occur in the output.

²⁾ Parallel gears with 12 stops are designed as a four step indexer, i.e. with each full rotation of the drive shaft, four indexes occur in the output.

³⁾ The additional load occurring with chains and belts due to friction is not taken into consideration here and must be calculated separately.

Technical Specifications

Main Dimensions

Shaft distance [mm]	100
Weight without drive [kg]	25
Switching angle [°]	see Load Table (other switching angles upon request)
Numbers of stops	1, 2, 3, 4, 5, 6, 8, 10, 12 (other numbers of stops upon request)
Rotating Direction	right, left, oscillating

Capacities

Max. Output torque	see Load Table
Input Shaft	
Load rating dynamic [kN]	40
Load rating static [kN]	28
Output shaft	
Load rating dynamic [kN]	40
Load rating static [kN]	28

Standard drive (optional)

Motor	SEW oder Kobold
Worm Gear	FRS70
Frame Size	IEC80
Voltage [V]	230/400
Performance [kW]	0,55-0,75

TP125

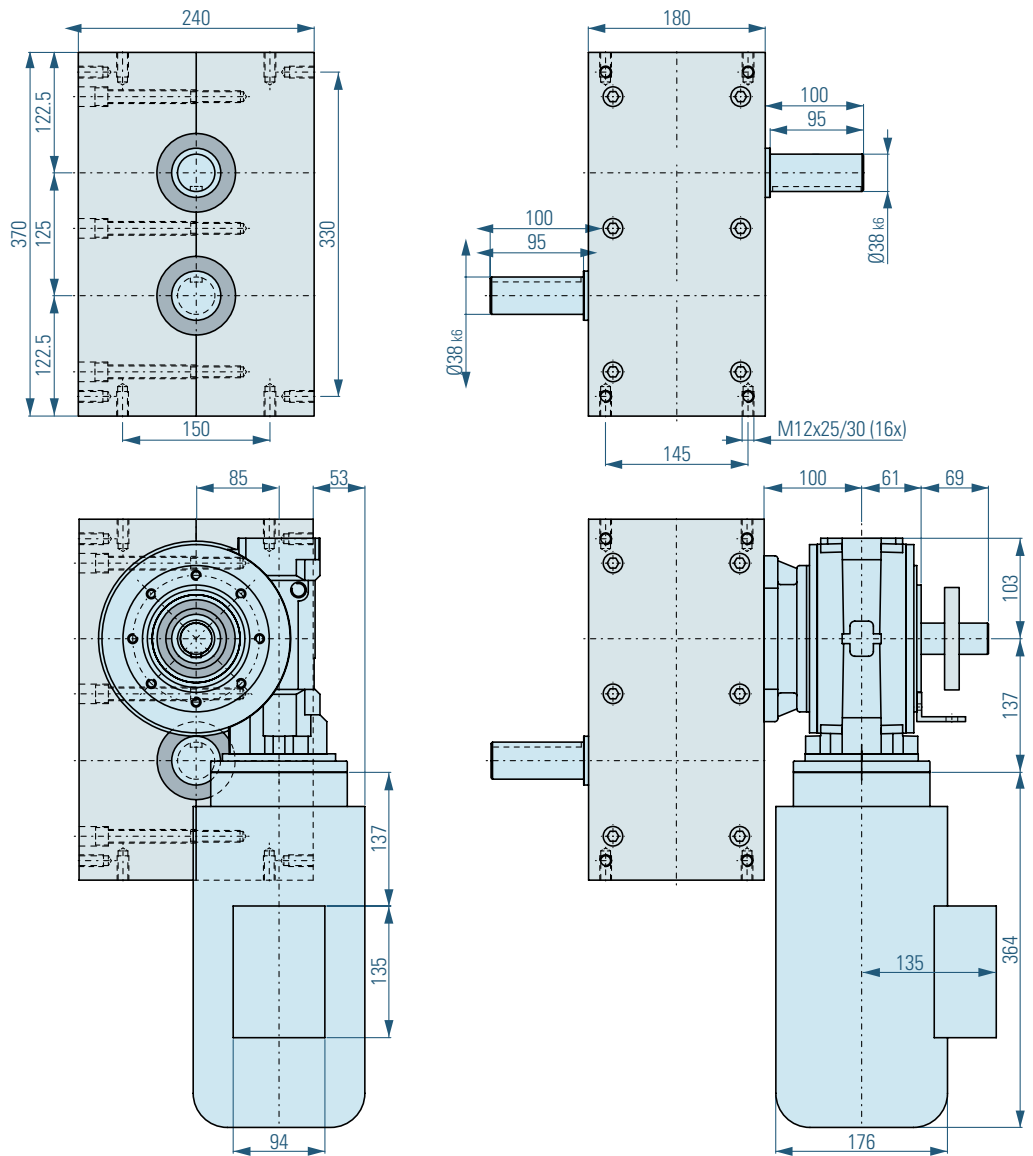

Dimensions

The measurements shown here illustrate the standard version. We will gladly customize the housing and the two shafts to suit your needs. The drive shaft as well as the output shaft is available as

double sided shafts with and without feather gear groove. If you would like to add additional boreholes into the housing yourself, please contact us for possible drilling depths.

- ⚠ Warning! Never drill through the housing.
- ⚠ Warning! Depending on the drive size used, the dimensions of the engine and drive may change.

A = Drive Shaft B = Output Shaft

Load Table XP125

Angle on Output Shaft [°]	Number of Stops n	Switching Angle α [°]	Acceleration Form MS	Engine Torque M_{AB} [Nm]			Moment of Inertia J [kgm ²]			Index Time t_s [s]		
				n=50	n=100	n=200	n=50	n=100	n=200	n=50	n=100	n=200
360°	1	330	MS30	349	282	221	6,7	1,4	0,3	1,10	0,55	0,28
		300	MS50	340	270	204	6,8	1,3	0,3	1,00	0,50	0,25
180°	2	270	MS0	436	360	294	14,1	2,9	0,6	0,90	0,45	0,23
		210	MS30	362	275	207	8,2	1,6	0,3	0,70	0,35	0,18
		150	MS50	301	222	160	2,4	0,4	0,1	0,50	0,25	0,13
120°	3	270	MS0	538	447	365	30,1	6,3	1,3	0,90	0,45	0,23
		210	MS30	505	424	350	14,8	3,1	0,6	0,70	0,35	0,18
		150	MS30	403	321	233	6,0	1,2	0,2	0,50	0,25	0,13
		120	MS30	379	277	204	3,6	0,7	0,1	0,40	0,20	0,10
90°	4	270	MS0	525	442	350	39,2	8,3	1,6	0,90	0,45	0,23
		210	MS0	487	401	316	22,0	4,5	0,9	0,70	0,35	0,18
		150	MS30	467	379	286	9,3	1,9	0,4	0,50	0,25	0,13
		90	MS30	428	336	256	3,1	0,6	0,1	0,30	0,15	0,08
72°	5	270	MS0	525	442	350	49,0	10,3	2,0	0,90	0,45	0,23
		210	MS0	487	401	316	27,5	5,7	1,1	0,70	0,35	0,18
		150	MS30	467	379	286	11,6	2,4	0,4	0,50	0,25	0,13
		90	MS30	428	336	256	3,8	0,8	0,1	0,30	0,15	0,08
60°	6 ¹⁾	270	MS0	598	522	430	66,9	14,6	3,0	0,90	0,45	0,23
		240	MS0	560	469	379	49,5	10,4	2,1	0,80	0,40	0,20
		180	MS30	433	358	272	18,6	3,8	0,7	0,60	0,30	0,15
		120	MS30	384	311	232	7,3	1,5	0,3	0,40	0,20	0,10
45°	8 ¹⁾	270	MS0	598	522	430	89,2	19,5	4,0	0,90	0,45	0,23
		240	MS0	560	469	379	66,0	13,8	2,8	0,80	0,40	0,20
		180	MS30	433	358	272	24,8	5,1	1,0	0,60	0,30	0,15
		120	MS30	384	311	232	9,8	2,0	0,4	0,40	0,20	0,10
36°	10 ¹⁾	270	MS0	598	522	430	111,5	24,3	5,0	0,90	0,45	0,23
		240	MS0	560	469	379	82,5	17,3	3,5	0,80	0,40	0,20
		180	MS30	433	358	272	30,9	6,4	1,2	0,60	0,30	0,15
		120	MS30	384	311	232	12,2	2,5	0,5	0,40	0,20	0,10
30°	12 ²⁾	240	MS0	350	282	224	61,9	12,5	2,5	0,80	0,40	0,20

¹⁾ Parallel gears with stop numbers 6, 8 and 10 are designed as a double indexer, i.e. with each full rotation of the drive shaft, two indexes occur in the output.

²⁾ Parallel gears with 12 stops are designed as a four step indexer, i.e. with each full rotation of the drive shaft, four indexes occur in the output.

³⁾ The additional load occurring with chains and belts due to friction is not taken into consideration here and must be calculated separately.

Technical Specifications

Main Dimensions

Shaft distance [mm]	125
Weight without drive [kg]	12
Switching angle [°] (other switching angles upon request)	see Load Table
Numbers of stops (other numbers of stops upon request)	1, 2, 3, 4, 5, 6, 8, 10, 12
Rotating Direction	right, left, oscillating

Capacities

Max. Output torque	see Load Table
Input Shaft	
Load rating dynamic [kN]	51
Load rating static [kN]	39
Output shaft	
Load rating dynamic [kN]	51
Load rating static [kN]	39

Standard drive (optional)

Motor	SEW oder Kobold
Worm Gear	FRS85
Frame Size	IEC90
Voltage [V]	230/400
Performance [kW]	1,1-1,5

TP160

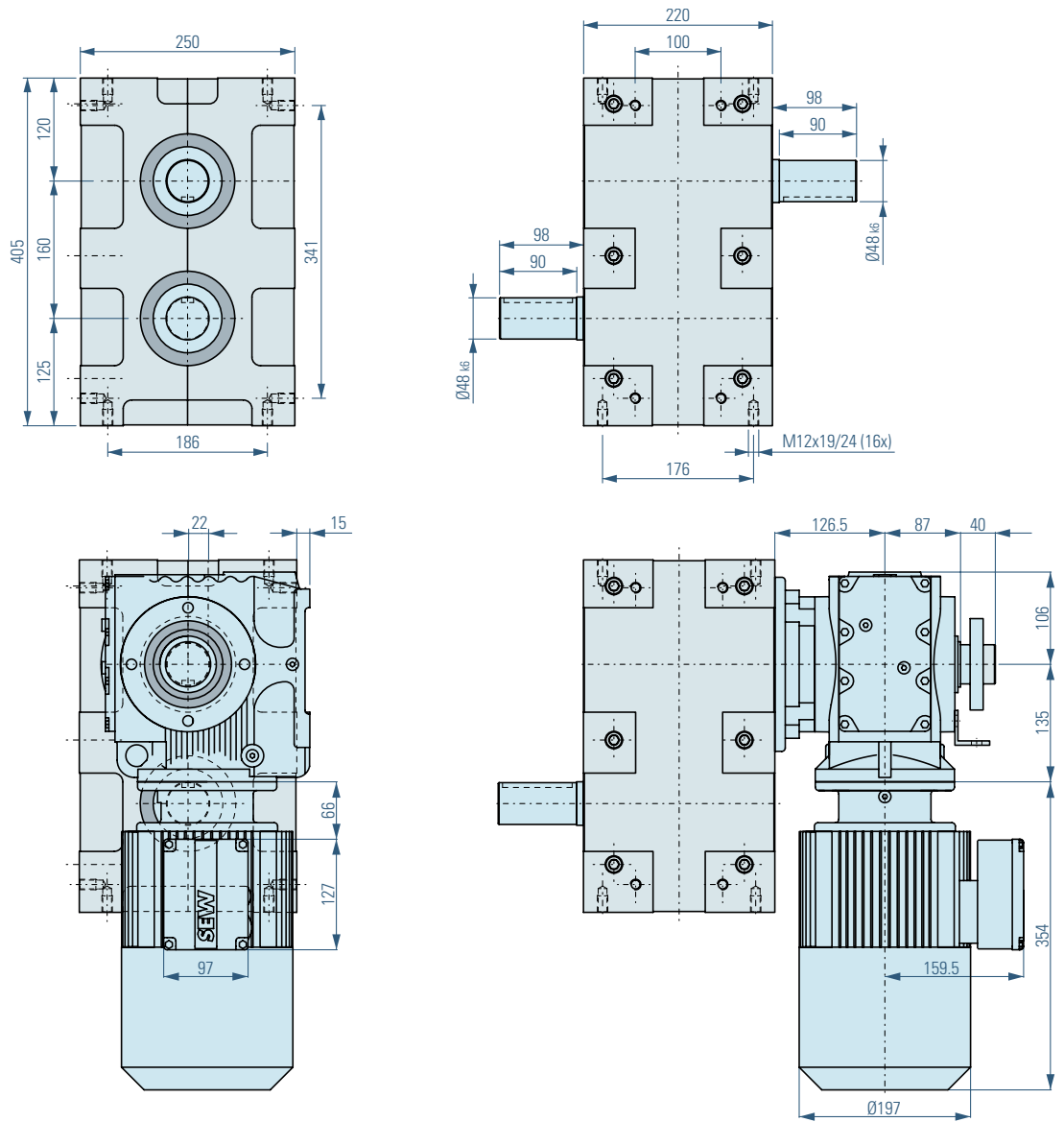

Dimensions

The measurements shown here illustrate the standard version. We will gladly customize the housing and the two shafts to suit your needs. The drive shaft as well as the output shaft is available as

double sided shafts with and without feather gear groove. If you would like to add additional boreholes into the housing yourself, please contact us for possible drilling depths.

- ⚠ Warning! Never drill through the housing.
- ⚠ Warning! Depending on the drive size used, the dimensions of the engine and drive may change.

A = Drive Shaft B = Output Shaft

Load Table TP160

Angle on Output Shaft [°]	Number of Stops n	Switching Angle α [°]	Acceleration Form MS	Engine Torque M_{AB} [Nm]			Moment of Inertia J [kgm ²]			Index Time t_s [s]		
				n=50	n=100	n=200	n=50	n=100	n=200	n=50	n=100	n=200
360°	1	330	MS30	894	739	598	17,2	3,6	0,7	1,10	0,55	0,28
		300	MS50	865	714	564	17,2	3,5	0,7	1,00	0,50	0,25
180°	2	270	MS0	904	816	661	29,1	6,6	1,3	0,90	0,45	0,23
		210	MS30	782	758	612	17,7	4,3	0,9	0,70	0,35	0,18
		150	MS50	768	719	583	6,1	1,4	0,3	0,50	0,25	0,13
120°	3	270	MS0	923	894	661	51,7	12,5	2,3	0,90	0,45	0,23
		210	MS30	816	787	573	23,9	5,8	1,0	0,70	0,35	0,18
		150	MS30	797	768	554	11,9	2,9	0,5	0,50	0,25	0,13
		120	MS30	782	748	525	7,5	1,8	0,3	0,40	0,20	0,10
90°	4	270	MS0	923	894	661	68,9	16,7	3,1	0,90	0,45	0,23
		210	MS0	816	787	573	36,9	8,9	1,6	0,70	0,35	0,18
		150	MS30	797	768	554	15,8	3,8	0,7	0,50	0,25	0,13
		90	MS30	782	748	525	5,6	1,3	0,2	0,30	0,15	0,08
72°	5	270	MS0	923	894	661	86,1	20,9	3,9	0,90	0,45	0,23
		210	MS0	816	787	573	46,1	11,1	2,0	0,70	0,35	0,18
		150	MS30	797	768	554	19,8	4,8	0,9	0,50	0,25	0,13
		90	MS30	782	748	525	7,0	1,7	0,3	0,30	0,15	0,08
60°	6 ¹⁾	270	MS0	904	894	865	101,2	25,0	6,1	0,90	0,45	0,23
		240	MS0	885	875	846	78,2	19,3	4,7	0,80	0,40	0,20
		180	MS30	865	855	826	37,1	9,2	2,2	0,60	0,30	0,15
		120	MS30	836	816	797	15,9	3,9	1,0	0,40	0,20	0,10
45°	8 ¹⁾	270	MS0	768	748	729	114,6	27,9	6,8	0,90	0,45	0,23
		240	MS0	748	729	710	88,3	21,5	5,2	0,80	0,40	0,20
		180	MS30	739	719	690	42,3	10,3	2,5	0,60	0,30	0,15
		120	MS30	729	710	700	18,5	4,5	1,1	0,40	0,20	0,10
36°	10 ¹⁾	270	MS0	768	748	729	143,3	34,9	8,5	0,90	0,45	0,23
		240	MS0	748	729	710	110,3	26,9	6,5	0,80	0,40	0,20
		180	MS30	739	719	690	52,9	12,9	3,1	0,60	0,30	0,15
		120	MS30	729	710	700	23,2	5,6	1,4	0,40	0,20	0,10
30°	12 ²⁾	240	MS0	710	700	680	125,5	31,0	7,5	0,80	0,40	0,20

¹⁾ Parallel gears with stop numbers 6, 8 and 10 are designed as a double indexer, i.e. with each full rotation of the drive shaft, two indexes occur in the output.

²⁾ Parallel gears with 12 stops are designed as a four step indexer, i.e. with each full rotation of the drive shaft, four indexes occur in the output.

³⁾ The additional load occurring with chains and belts due to friction is not taken into consideration here and must be calculated separately.

Technical Specifications

Main Dimensions

Shaft distance [mm]	160
Weight without drive [kg]	117
Switching angle [°]	see Load Table
(other switching angles upon request)	
Numbers of stops	1, 2, 3, 4, 5, 6, 8, 10, 12
(other numbers of stops upon request)	
Rotating Direction	right, left, oscillating

Capacities

Max. Output torque	see Load Table
Input Shaft	
Load rating dynamic [kN]	51
Load rating static [kN]	39
Output shaft	
Load rating dynamic [kN]	168
Load rating static [kN]	270

Standard drive (optional)

Motor	SEW oder Kobold
Worm Gear	SAF67
Frame Size	IEC100
Voltage [V]	230/400
Performance [kW]	2,2-3,0

Universal Controller TIC

Your Advantages

An index table can be controlled in many different ways. We have developed this universal control to provide our customers with a user-friendly tool for operating the rotary table requiring minimal effort on the operator's part.

- Cycle time optimization is a result of stopping the drive exactly at the end of the dwell phase. The machine control receives the "enable" signal for the external processes as soon as the dwell phase begins. Elimination of time losses typically caused by mechanical contactors and variable PLC cycle times.
- Reduced installation and hardware costs.
- Motor contactor switches and mechanical or electronic contactors can be omitted. Only wiring protection is required.
- Single phase motor operation up to 2 kW possible.
- Fast, friction-free braking for emergency stop conditions.
- Gentle (soft) restart from intermediate positions or from an emergency stop.
- Soft and wear-free manual operation possible.
- Oscillating or change in direction of rotation possible without additional hardware.
- Speed can be easily changed.
- No frictional braking. The brakes only engage and lock after an emergency stop.
- When the TIC is used the rotary index table requires no maintenance.
- Short start-up times result, as the rotary index table software has already been initialized and integrated into the controller.
- Simple hand-shaking with the customer control unit (only start, stop & error signals).
- Simple interface between machine and rotary index table means quick error analysis via the telephone saving time and expensive servicing.



Schematic for single phase model

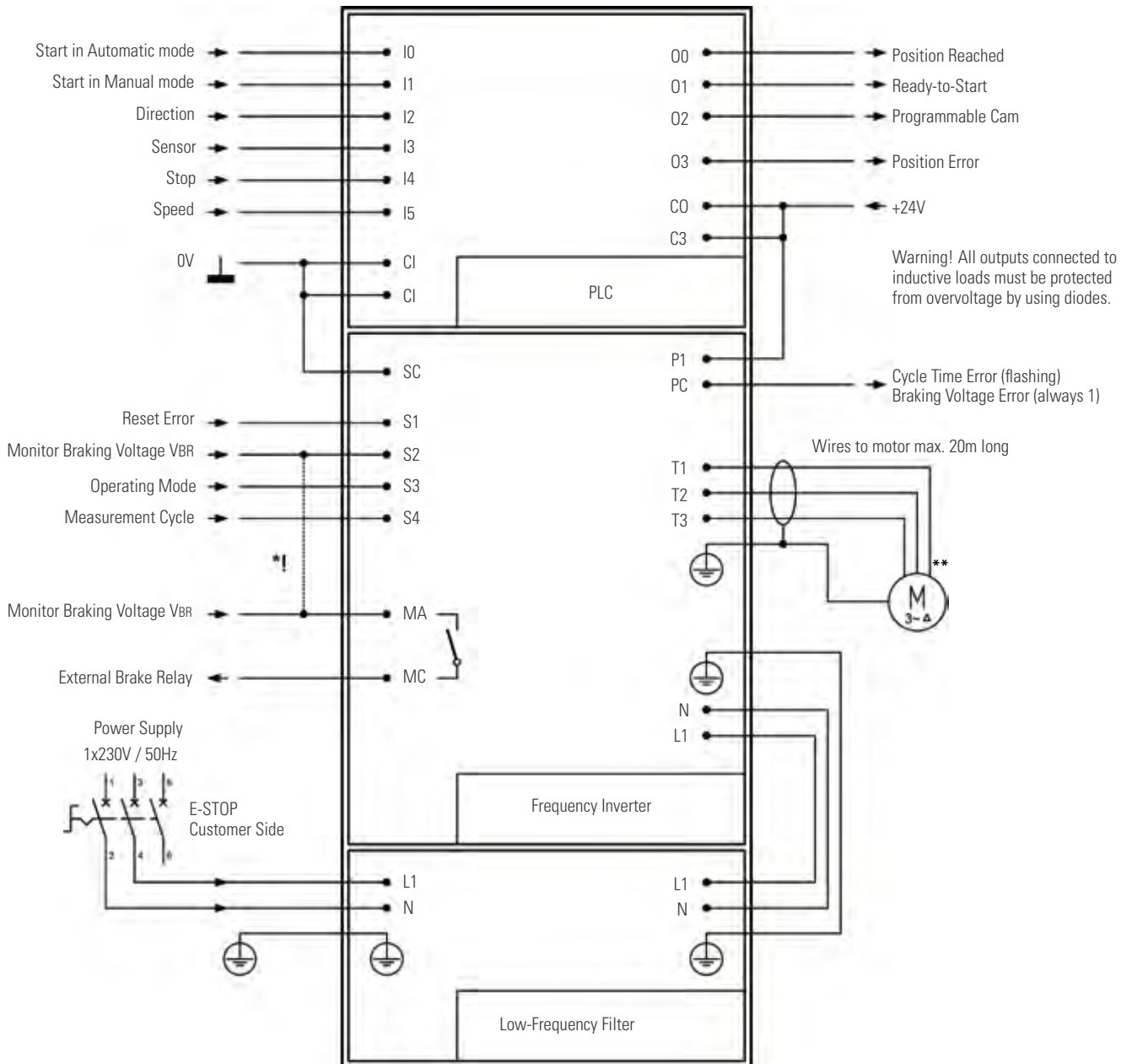

*!! Warning! If using brakes with a supply voltage of 230VAC or 400VAC, a jumper is NOT allowed between MC and S2. In this case S2 must be connected directly to +24V DC. Braking voltage monitoring is then no longer possible. Hence we strongly recommend a 24V DC brake when using this rotary index table.



** If a standard 230/400VAC three phase electric motor is interfaced to our single phase rotary index table controller TIC, a delta connection must be used. Please refer here to the description on the motor terminal block.

Quotation and order form parallel indexer (1)

Company _____
 Administrator _____
 Telephone/Fax _____

E-Mail address _____
 Project/Order no. _____
 Date _____

Applications

- Belt or chain conveyor Pivot arm
 Rotation of parts Other (please include drawing)

Belt or chain conveyor

Gear ratio (if applicable) $i=$ _____
 Feed length _____ Distance of deflexion pulleys _____
 Number of work piece carriers _____

Deflexion pulleys

Quantity _____ \emptyset _____ Thickness _____
 Material or weight _____

Belt / Chain

Weight _____ Friction coefficient _____
 Work piece carrier weight _____

Work piece

Quantity _____ Weight _____

Pivot arm

Pivot angle _____ Number of arms _____
 Distance from pivot point to centre of mass of acceptance _____
 Weight of one arm _____
 Weight of fixture and work piece _____

Rotation of parts

Rotation angle _____ Weight of fixture and work piece _____

Stepping operation (cycle time fixed, resting time variable)

Continuous motion (cycle and resting time fixed)

Desired index time [s] $t_s=$ _____

Desired dwell time [s] (continuous motion only) _____

Number of indexes [1/min] _____

Required lifetime (cycle time only, typically 12,000 h) _____

Additional forces and loads (please describe)

Scheibenkurven-Schrittgetriebe

Type XP TP

Frame Size _____

Number of Stops $n=$ _____

Switching angle $\alpha=$ _____

Mounting side of nameplate (Standard 3) _____

Standard Input shaft yes no

If no, deviations _____ mm

Standard output shaft yes no

If no, deviations _____ mm

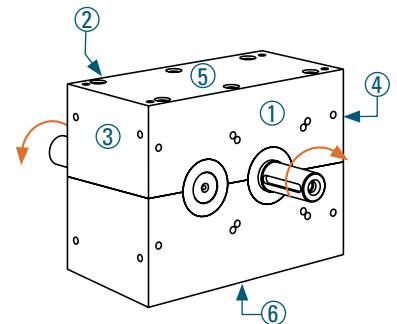

Mounting side of nameplate / Direction of rotation of input and output shaft

Quotation and order form parallel indexer (2)

Possible mounting positions for the drive units

SL-0

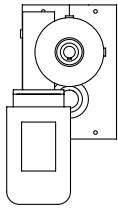

SL-90

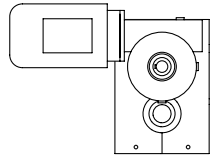

SL-180

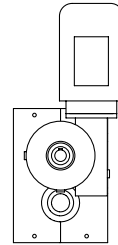

SL-270

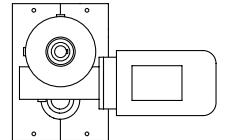

SR-0

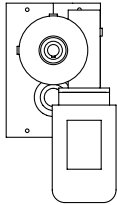

SR-90

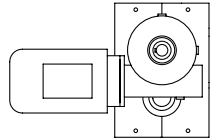

SR-180

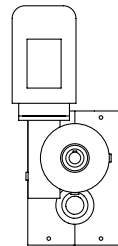

SR-270

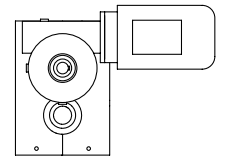

Drive

with Drive

without drive

Mounting Position (see above) _____

Terminal Box Position (see right) _____

Voltage Motor

230/400-50 Hz

different Voltage _____

Voltage Brake

24V DC

different Voltage _____

Manual release on brake Yes No

Motor Handwheel Yes No

Input Safety Clutch Yes No

Additional specifications (temperature sensor, connector assembly, brand..)

Terminal Box Position

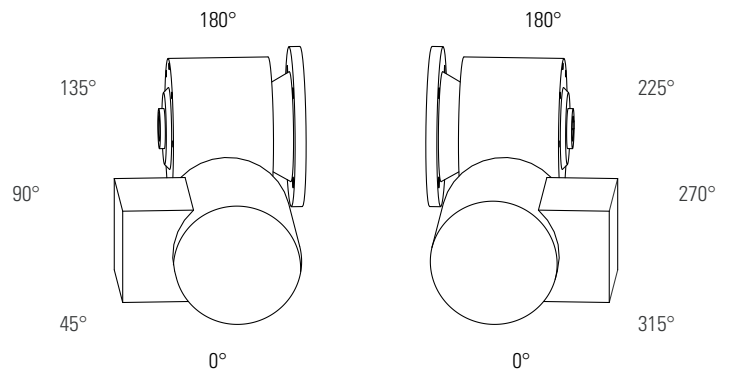

Universal Controller TIC

Universal Controller TIC Yes No

TAKTOMAT

passion for automation

Rudolf-Diesel-Str. 14 D 86554 Pöttmes Tel +49 (0)82 53-99 65-0 Fax +49 (0)82 53-99 65-50
info@taktomat.de www.taktomat.de

In Kooperation mit:

Motion
INDEX DRIVES, INC.