

LEINE  LINDE

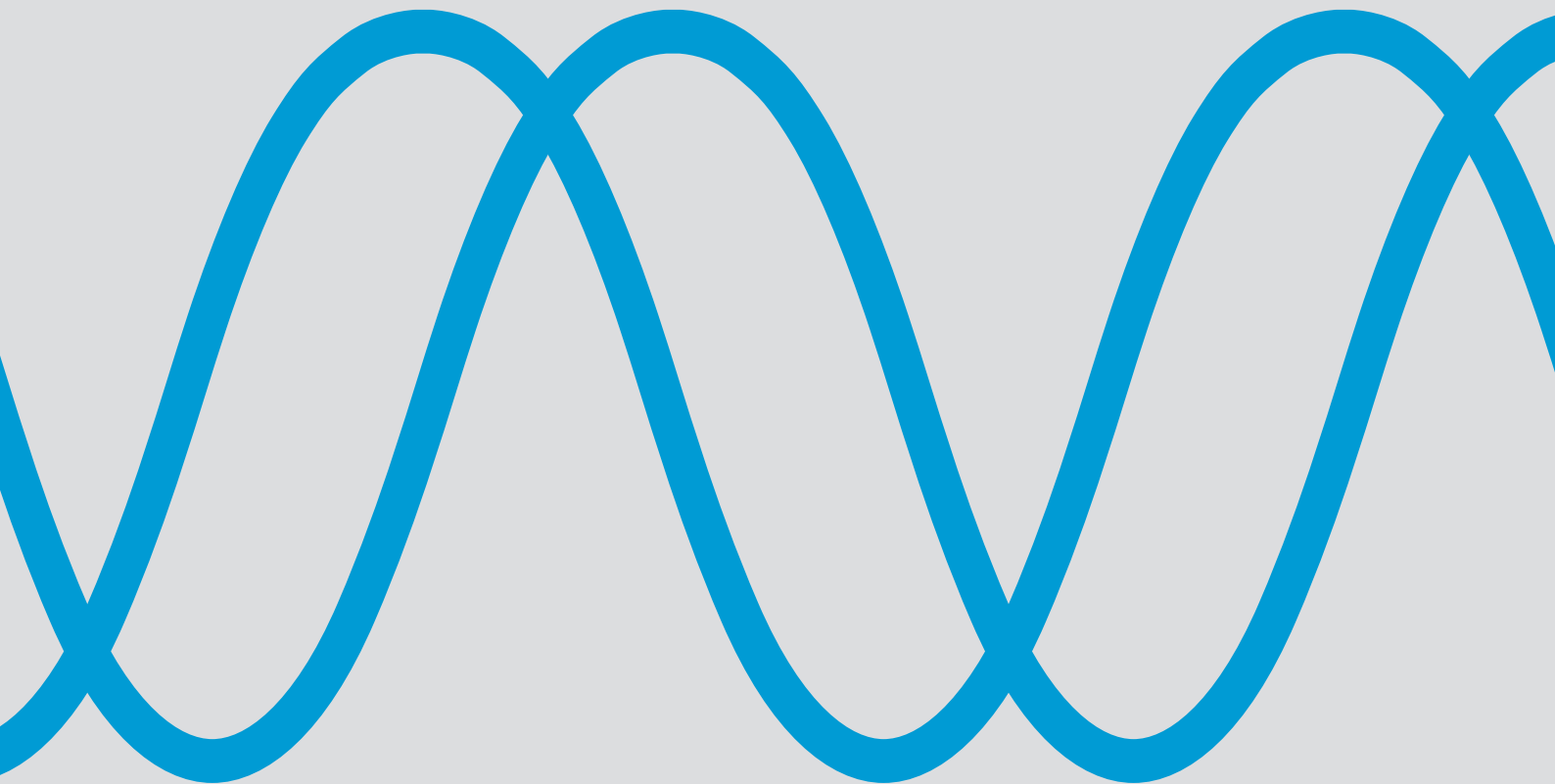

# ENCODER TECHNOLOGY

DETAILS & DESCRIPTIONS

## Contents

<b>1 QUALITY</b>	<b>5</b>
1.1 QUALITY POLICY	5
1.2 ENVIRONMENTAL POLICY	5
1.3 EXTERNAL CERTIFICATES	5
1.3.1 ATEX / IECEx	5
1.3.2 UL / CSA standards, type approval	5
1.3.3 CE marking and Declaration of Conformity	5
1.3.4 Functional safety	6
<b>2 USE OF ENCODERS</b>	<b>6</b>
2.1 INCREMENTAL ENCODERS FOR SPEED FEEDBACK OR RELATIVE POSITIONING	6
2.2 ABSOLUTE ENCODERS FOR POSITIONING OR DIGITAL SPEED	6
<b>3 PRODUCTS</b>	<b>7</b>
3.1 PRODUCT INFORMATION	7
3.1.1 300 series Miniature	7
3.1.2 500 series Robust	7
3.1.3 600 series Industrial	7
3.1.4 700 series Compact	7
3.1.5 800 series Heavy duty	7
3.1.6 900 series Premium	8
3.1.7 1000 series Extreme	8
3.1.8 2000 series Magnetic	8
3.1.9 Accessories	8
<b>4 ENCODER TECHNOLOGY</b>	<b>9</b>
4.1 MEASURING PRINCIPLES	9
4.1.1 Photoelectric scanning	9
4.1.2 Inductive measuring scanning	9
4.2 ABSOLUTE ENCODERS MEASURING PRINCIPLE	9
4.3 INCREMENTAL ENCODERS MEASURING PRINCIPLE	10
4.3.1 Resolution, line count and pulse rate	10
4.3.2 Measuring steps	10
4.3.3 Accuracy	10
4.3.4 Channel separation on incremental encoders	11
4.3.5 Bearing lifetime / Shaft load	11
4.3.6 Vibration	12
4.3.7 Shock	12
4.3.8 Humidity	12
4.3.9 Moment of inertia	12
4.3.10 Natural frequencies	12
4.3.11 Magnetic fields	12
4.3.12 Encapsulation	13
4.3.13 Surface treatment	13
4.3.14 System tests	13
4.3.15 Assembly	13
4.3.16 Temperature ranges	13
4.3.17 Power supply	13
4.3.18 Electrically permissible speed / Traversing speed	14

4.3.19 Electromagnetic compatibility / CE compliance	14
4.3.20 Protection against electrical noise	14
4.3.21 Cables	14
4.3.22 Bending radius	15
<b>5 INTERFACES</b>	<b>16</b>
5.1 INCREMENTAL INTERFACES	16
5.1.1 TTL electronics / RS422	16
5.1.2 HTL and HCHTL electronics	16
5.2 INCREMENTAL SIGNALS 1 VPP	18
5.2.1 Interpolation / Resolution / Measuring step	18
5.2.2 Short-circuit stability	18
5.2.3 Input circuitry of the subsequent electronics	18
5.3 ADS 19	
5.3.1 ADS Classic	19
5.3.2 ADS Online	20
5.4 ABSOLUTE ELECTRICAL INTERFACES	21
5.4.1 Parallel interface	21
5.4.2 Analog interface	21
5.4.3 BiLL interface (RS485 based)	21
5.4.4 Serial point-to-point interfaces	21
5.4.5 EnDat 2.1 interface	21
5.4.6 EnDat 2.2 interface	22
5.4.7 SSI interface	23
5.5 FIELDBUS INTERFACES	24
5.5.1 PROFIBUS DP	24
5.5.2 PROFINET IO	25
5.5.3 CANopen	25
5.5.4 DeviceNet	26
5.5.5 DRIVE-CLiQ	27

**Leine &Linde AB claims copyright on this documentation.** It is not allowed to modify, extend or to hand over to a third party and/or copy this documentation without written approval from Leine&Linde AB.

Specifications and content in this document are subject to change without prior notice due to our continuous strives to improve functionality and performance of our products.

## 1 Quality

Quality and the environment have for a long time been critical priorities at Leine &Linde. The company has been certified according to ISO 9001 since 1995. This includes the continuous follow-up and evaluation of our internal processes as well as the complete analysis and appraisal of all related data; to produce fact-based improvement measures.

All activities at Leine &Linde are characterized by an awareness of our environment and the impact our activities cause. This impact is regulated through well thought-out choices when introducing new products, equipment and materials as well as through a carefully prepared program for waste disposal. Leine &Linde is certified according to ISO 14001 since 2002. Leine &Linde consider this environmental work as strategically important and it is demonstrated by the environmental policy.

### 1.1 Quality policy

One of Leine &Linde's most important competitive advantages is quality. Superior quality results in a strong commitment with our customers.

This is achieved through:

- Measurable targets and plans of action
- Follow-up and continuous improvement
- Well defined internal communication
- Participation and input from all business units
- A continuous process of improving the management system

Contributing to our ambition "quality at the appointed time".

For our customers this can be interpreted as the mutual co-operation in the transformation from their requirements to the development of specific product features and continuous dialogue after the delivery and installation of the product. Internally the policy is translated as an active co-operation with our suppliers, ongoing efforts to improve our internal processes and involvement of all parts of the company.

### 1.2 Environmental policy

Actively working to minimize the environmental impact on our surroundings is considered a strategically important position for Leine &Linde.

This work involves:

- economizing on energy, water and other natural resources
- following existing environmental legislation
- continuously increasing employees' environmental knowledge and promoting their commitment
- selecting the best technology and materials from an environmental standpoint
- minimizing the amount of waste and emissions from operations
- continuously improving our environmental work through defined environmental goals and follow-up evaluation

This results in a working climate that favours both people and the environment.

## 1.3 External certificates

### 1.3.1 ATEX / IECEx



All standard products comply with the requirements for zone 2/22. There are also specific flameproof models intended for use in the more hazardous zone 1/21.

### 1.3.2 UL / CSA standards, type approval



Most Leine &Linde products have been type tested in accordance with IEC 61010. The product box label states if the product conforms to the standard. When the product is to be operated in accordance with IEC 61010-1, the power must be supplied from a secondary circuit with current or power limitation as per IEC 61010-1:2001, section 9.3, IEC 60950-1:2005, or by a class 2 secondary circuit as specified in UL 1310.

### 1.3.3 CE marking and Declaration of Conformity



Leine &Linde standard products in the 300, 500, 600, 700, 800, 1000 and 2000 series, including the accessories conform with the protection requirements of Council Directive 2004/108/EC related to EMC when applicable. Please contact Leine &Linde to obtain Declaration of Conformity for unique encoder variants.

### 1.3.4 Functional safety

Leine & Linde offers reliability values for standard encoders, with either 1 Vpp or HTL and HCHTL signals. The calculated  $MTTF_d$  and  $PFH_d$  values are for use in functional safety system according to EN ISO 13849-1 or according to EN IEC 62061/IEC 61508.

## 2 Use of encoders

An encoder can be either incremental or absolute.

### 2.1 Incremental encoders for speed feedback or relative positioning

An incremental encoder usually generates a series of pulses in response to a linear or rotary motion. These pulses can be used to measure speed or be fed to a PLC or counter to keep track of a relative position. The output signal of an incremental encoder is normally an electrical square wave signal with a certain frequency related to the speed of the encoder shaft.

### 2.2 Absolute encoders for positioning or digital speed

Absolute rotary encoders generate a position value that indicates the actual position of the encoder shaft directly. A major benefit of absolute encoders is that if the application loses power, the encoder is able to keep track of its position also if the shaft is turned during the power loss. This is due to the genuine absolute scanning principle. An absolute encoder can also be used to calculate a digital speed value. By internally dividing the difference in position with a small delta time an accurate speed value can be calculated and transmitted to the subsequent electronics.

Other types of encoders such as tachometers, i.e. an encoder with analog current outputs (0-20 mA or 4-20 mA) related to the speed or position of its shaft, may also be offered from Leine & Linde. Thus the principle function of the encoder is always the same, i.e. an encoder converts a mechanical movement of its shaft into an electrical measurable unit representing the shaft's speed or position.

Encoders are often used on electrical motors in the paper and steel industries, cranes and material handling systems as well as various types of measurement, testing and inspection systems. The pictures below show some of the applications.



## 3 Products

### 3.1 Product information

Leine & Linde offer robust encoder solutions suitable for many different kinds of applications. Where the applications demand specific requirements, Leine & Linde is the right partner for customized encoder design. The series of encoders are described below, for information related to customized encoders you are welcome to contact us for more information.

#### 3.1.1 300 series Miniature



The model 300 series consists of robust and extremely reliable miniature encoders, 30 mm in diameter and designed for installation in applications where limited

space is at a premium. Various types of incremental electrical interfaces including TTL, HTL and RS422 are supported by the series. Some typical applications are in wood harvesting apparatus and industrial high-pressure washing equipment. The series' high encapsulation level, IP67 and its shock and vibration resistant design, guarantees long life and ensures a durable sensor solution with high dependability.

#### 3.1.2 500 series Robust



"Versatile" and "modular" are catchwords that differentiate the incremental and absolute encoders in the model 500 series. Used in a variety of different industrial applications such as on electric motors, cranes, elevators or in general automation, the series' mechanical, optical and electrical interfaces have become industry standard. If the standard selection of interfaces does not suit the application's particular requirements, customized and cost-effective solutions may be provided with very short lead times.

#### 3.1.3 600 series Industrial



Fieldbus interfaces based on Ethernet, PROFIBUS or CAN are examples of communication protocols used in automation. These interfaces are available on the 600 series of absolute coded singleturn or multiturn encoders. A robust mechanical design in shaft or hollow shaft design ensures that

installation and commissioning of these encoders are reduced to a minimum. Serial point-to-point interfaces such as EnDat or the popular SSI interface are other examples of other communication protocols used for position feedback from an absolute coded encoder in the 600 series.

#### 3.1.4 700 series Compact

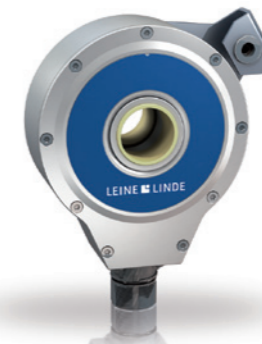

The 700 series is a robust encoder with a compact design. With its short length, it is designed for filling the need for heavy duty encoders even in installations where space is limited. Despite its compactness, the series is nevertheless designed for the tough environments where typical

Leine & Linde products are used. The 700 series is available with large hollow shafts up to 25.4 mm and with many variant in sizes the market for both inch- and millimeter-based dimensions are covered.

#### 3.1.5 800 series Heavy duty

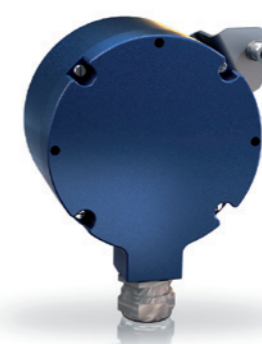

When the most robust, maintenance-free and cost-effective encoder solution is required, the model 800 series is the first choice of most engineers. The optional ADS (Advanced Diagnostic System) is a built-in system tailored to support condition-based maintenance, guaranteeing

the reliability of the application. The 800 series is designed to operate in heavy duty industries, which

place stringent demands on robustness and reliability of the encoder. Mechanically it features a dual set of heavy duty bearings and a well-encapsulated enclosure. The electronics are designed to withstand an environment where it is exposed to powerful vibrations, electronic disturbances, etc.

### 3.1.6 900 series Premium



Machines are becoming more and more advanced in classical industrial applications. More complex motions need to be monitored in order to achieve full process control. To meet this increasing demand the 900 series is a heavy duty encoder based on absolute scanning which enables position feedback with

high resolution. It is available with advanced communication protocol for transfer of detailed data into the required system. Except the premium performance to withstand high temperatures and moisture or vibration and shock the 900 series offers a variety of different shafts, connectors and communication interfaces.

### 3.1.7 1000 series Extreme



There are many examples of extreme environments within the steel industry in the terms of temperature, mechanical forces, vibrations and shocks. The 1000 series is designed with exceptional durability, suited to an exposed environment. This due to the high encapsulation level which keeps the internal parts protected

from dust and liquids. There are different versions available of the 1000 series, in combination of both incremental and absolute signals or redundant signals: 2 x incremental or 2 x absolute.

### 3.1.8 2000 series Magnetic



The 2000 series is bearing-less incremental encoder rings suitable where shaft dimensions may be very large. With an accepted air gap of up to 2.6 mm the 2000 series offers several

times better performance than most ring products found on the market. The Leine & Linde ring is segmented into pieces, something that facilitates commissioning and service. As the ring is often mounted on a shaft between other parts in the machinery it may be difficult to access it, both when first mounting it and when performing service. With a segmented ring the pieces may be mounted from two sides of the shaft and screwed together or clamped together with a clamping fit solution. The interfaces High Current HTL, TTL, RS422 and integrated Optolink are available.

### 3.1.9 Accessories



Connectors, shaft couplings, draw-wire units and measuring wheels are just some parts in Leine & Linde's line of accessories. Accessory cables, connectors and all

the other accessories that may be used in an application should always maintain the same high quality as the encoders Leine & Linde deliver. The best way to guarantee that the accessories are of this quality is to only use original accessories that have been verified regarding function and performance, and offered as Leine & Linde accessories.

## 4 Encoder technology

### 4.1 Measuring principles

Leine & Linde encoders based on optical scanning incorporate measuring standards of periodic structures known as graduations. These graduations are applied to a carrier substrate of glass, unbreakable plastic or other materials. These precision graduations are manufactured in photolithographic processes. The photolithographic processes permit very fine grating periods and are characterized by a high definition and homogeneity of the line edges. Together with the photoelectric scanning method, this high edge definition is a precondition for the high quality and accuracy of the output signals.

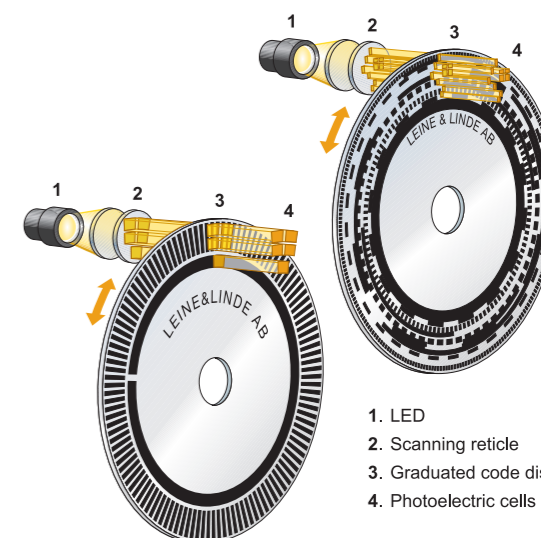

1. LED
2. Scanning reticle
3. Graduated code disc
4. Photoelectric cells

#### 4.1.1 Photoelectric scanning

This method detects very fine lines, no more than a few micrometers wide, and generates output signals with very accurate signal periods. The photoelectric scanning of a graduated code disc is contact-free, and therefore without wear.

Put simply, the photoelectric scanning principle functions by means of projected-light signal generation: The output signal is generated when two graduations with equal grating periods are moved relative to each other, the graduated code disc and the scanning reticle.

The carrier material of the scanning reticle and code disc is transparent, whereas the graduation may be transparent or non-transparent. When parallel light passes through a grating, light and dark surfaces are projected at a certain distance and when the two gratings move relative to each other, the incident light is modulated. If the gaps in the gratings are aligned, light passes through. If the lines of one grating coincide with the gaps of the other, no light passes through. Photovoltaic cells convert these variations in light intensity into nearly sinusoidal electrical signals.

#### 4.1.2 Inductive measuring scanning

Besides the optical scanning, Leine & Linde offers encoders with inductive scanning.

Electromagnetic inductance means that electric current is generated in an electrical conductor, if a magnetic field varies within its present. This technique results in an intern signal generation insensitive to impact and dirt.

### 4.2 Absolute encoders measuring principle

With the absolute measuring principle, either optical or inductive, the position value is available from the encoder immediately upon power-on and can be called at any time by the subsequent electronics. There is no need to move the axis to find a reference position. Some absolute encoders are available with additional incremental signals.



Optical absolute code disc.

On singleturn encoders the absolute position information repeats itself with every revolution. Multiturn encoders can also distinguish between the numbers of absolute revolutions by the use of an internal gearbox.

### 4.3 Incremental encoders measuring principle

With the incremental measuring principle, the graduation consists of a periodic grating structure producing a defined number of sinusoidal signals when the encoder shaft is rotated. These sinusoidal signals can be converted into other signal formats and used in two different ways. Either for relative positioning or more commonly as speed feedback devices. Relative position information can be obtained by counting the individual increments (measuring steps) from some point of origin. When such a semi-absolute reference is required to ascertain positions, the graduated discs are provided with an additional track that bears a reference mark.



Incremental graduated code disc.

The rotational speed of the encoder shaft can be determined by calculating the frequency of the sinusoidal signals. Incremental encoders are normally used in closed loop, speed control loops or as speed feedback devices.

#### 4.3.1 Resolution, line count and pulse rate

The resolution, line count or pulse rate are just different designations of the number of signal periods per channel and per revolution of an incremental encoder. Denominations of these signals vary between encoder manufacturers but Leine & Linde commonly use S00, S90 and Sref. The signals S00 and S90 are 90 el° displaced from each other. S00 appear 90 el° before S90 when the encoder shaft is turned clockwise. A, B and N or K1, K2 and K0 are other examples of denominations used on incremental signals.

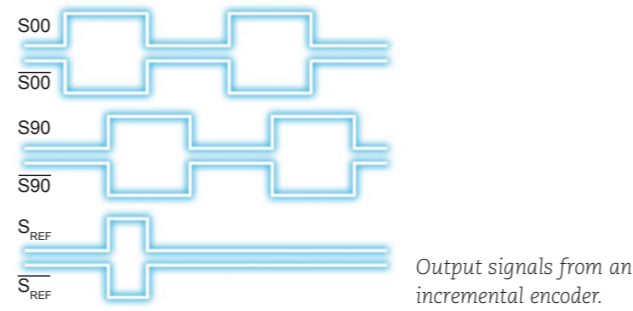

Output signals from an incremental encoder.

For absolute encoders, resolution is stated as the number of bits. The number of bits (or unique positions per revolution) is calculated as  $2^n$  where n equals the number of bits. The total resolution of multiturn encoders also includes the number of distinguishable revolutions.

#### 4.3.2 Measuring steps

In order to obtain higher resolutions from an incremental encoder, evaluation of all raising and falling pulse edges may be monitored. This is normally done by subsequent electronics as a quadruple, double or single evaluation. A measuring step is the definition of maximal number of edges as acquired when the subsequent electronics support quadruple evaluation, i.e. maximal measuring steps = 4 x line count. The example below indicates what different measuring step evaluation results in as seen by the subsequent electronics. In the example a 1024 ppr line count disc is used.

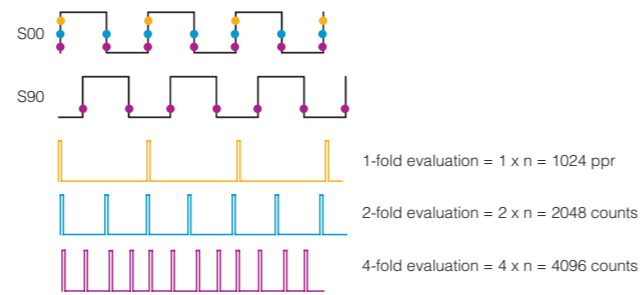

Edge evaluation of incremental signals.

#### 4.3.3 Accuracy

The accuracy of measurements with encoders is mainly determined by:

- Directional deviation of the radial grating
- Eccentricity of the graduated disc to the bearing
- Radial deviation of the bearing
- Error resulting from the mechanical installation
- Interpolation error during signal processing in the integrated or external interpolation and digitizing electronics.

When speaking about accuracy of incremental encoders, the unit el° (electrical degrees) is normally used. For one signal period of the output signal is the equivalent of 360 el°. One revolution of the encoder equals  $360 \cdot N$  el°, where N is equal to the number of lines on the graduated disc (ppr).

Incremental encoders from Leine & Linde have a maximal permissible accuracy of  $\pm 50$  el° (dividing error) which means that each pulse edge of the encoder signal has a deviation from its theoretical angle position of a maximum of  $50/N$ °. As an example, for an encoder with 5000 ppr,  $\pm 50$  el° corresponds to 0.01° maximum mechanical angle deviation from the theoretical position for each of the 20,000 pulse edges. (The encoder's highest resolution is in this case  $360/(5000 \cdot 4)$  or 0.018°).

The dividing error is always sinus-shaped. One half of the revolution the pulses will have a shorter signal period where as the signal period will be a little longer for the other half of the revolution. If an incremental encoder is used in a speed control loop and has a high dividing error, may this be seen as a speed ripple.

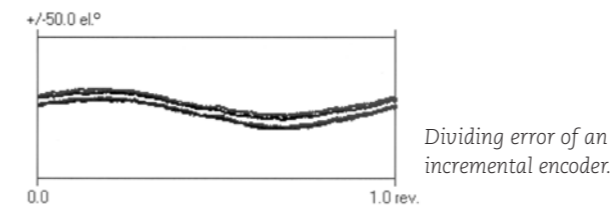

Dividing error of an incremental encoder.

For absolute encoders the term accuracy relates to the deviation from the absolute encoders optimal theoretical position. The unit used for accuracy of an absolute encoder is LSB, Least Significant Bit. On an absolute encoder with 13 bit singleturn resolution ( $2^{13} = 8192$  position) the accuracy is  $\pm 1$ LSB which implies that the maximal mechanical angle deviation is:  $360^\circ / 8192 = \pm 0.04^\circ$

Accuracy and calibration charts for each delivered encoder can be provided upon request.

#### 4.3.4 Channel separation on incremental encoders

The specification of accuracy also includes the term channel separation, which is the distance between adjacent pulse edges of the S00 and S90 output signals. During final adjustments this is tuned to 90 el° and should lie within  $90 \pm 25$  el° for standard encoders. This means that the distance between adjacent pulse edges can vary between 65 el° and 115 el° for

an approved encoder. Channel separation error is included in the dividing error.

The duty cycles of all incremental encoders are 180 el° or 1:1 unless stated otherwise.

Every delivered encoder is verified with respect to their accuracy, channel separation and duty cycle accomplished by monitoring that all pulse edges lies within approved limits. The measured values for maximum deviations from the encoder specifications are referred to the encoder's serial number and collected in a database for statistical follow-up and future reference.

All accuracy data refer to measuring signals at an ambient temperature of 20°C, and with controlled subsequent electronics and transmission lines.

#### 4.3.5 Bearing lifetime / Shaft load

The lifetime of an encoder depends partially on its shaft bearings. Several other environmental parameters influence the lifetime such as shaft load, shaft speed, point of force and ambient temperature, among other things. The bearings used within Leine & Linde encoders are always utilized by high-quality permanent lubricated bearings. The encoder has a defined lifetime and need to be replaced at certain time intervals to ensure proper function. If the bearings are subjected to considerable static or dynamic load, the limiting factor will be normal bearing wear, i.e. surface fatigue of the ball race rather than lack of lubrication. The permissible nominal dynamic shaft loads are given in each model's data-sheet - these value are based on a recommended service life of approximately 50,000 hours calculated at 1500 rpm nominal speed.

The simplified diagram below shows an example of how the bearing lifetime is affected at various loads for the different encoder series.

The  $F_r$  and  $F_a$  values for each encoder series can be found in its respective datasheet. Example, a 503 series encoder has a permissible radial force  $F_r$  equal to 60 N. This corresponds to 100% in the graph. If the force is reduced to 30 N the  $F_r = 50\%$  in the graph. See column on next page.

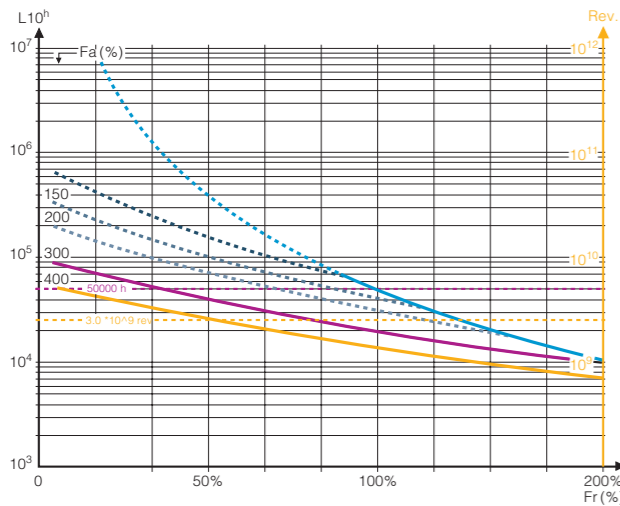

Permissible shaft load and lifetime relation.

**Note:** High-quality shaft-coupling shall always be used on solid shaft encoders in order to reduce shaft loads and optimize the lifetime of the encoder. When measuring wheels are used or if shaft loads are unavoidable, separate bearing boxes should be used to minimize the shaft load. Bearing boxes are offered as accessories to complement the Leine & Linde encoder. Never exceed twice the specified maximum shaft load.

### 4.3.6 Vibration

Encoders are subject to various types of vibrations during operation and mounting. The indicated maximum values for vibration apply for frequencies between 55 to 2000 Hz (IEC 60 068-2-6). Any vibrations exceeding the permissible values, for example due to resonance depending on the application and mounting, might damage the encoder.

The permissible angular acceleration for all encoders is over  $10^5 \text{ rad/s}^2$ . The maximum values for vibration and shock indicate the limits up to which the encoder can be operated without failure.

In order to achieve the highest potential accuracy of an encoder, the environmental and operating conditions need to be optimized.

### 4.3.7 Shock

Comprehensive tests of the entire system are often required. The maximum permissible vibrations values (semi-sinusoidal shock) for shock and impact are valid for 6 ms (IEC 60 068-2-27). Under no circumstances should a hammer or similar device be used to adjust or position the encoder.

If the application includes increased shock and vibration loads, please ask for assistance from Leine & Linde.

### 4.3.8 Humidity

The maximal permissible relative humidity is 75%. 95% is permissible temporarily. Condensation is not permissible. Measures to permit higher humidity are available upon request.

### 4.3.9 Moment of inertia

The moment of inertia of the encoder series are in accordance with the table below. Note that the values may vary slightly from unit to unit.

Encoder series	Moment of inertia [kgm <sup>2</sup> ]
300	$0,15 \times 10^{-6}$
500	$2,0 \times 10^{-6}$
600	$4,3 \times 10^{-6}$
700	$105 \times 10^{-6}$
800	$55 \times 10^{-6}$
1000	$0,32 \times 10^{-6}$

### 4.3.10 Natural frequencies

Hollow shaft encoders with their stator couplings form a vibrating spring mass system whose natural frequency  $f_n$  should be as high as possible.

A prerequisite for the highest possible natural frequency on shaft encoders is to use a coupling with a high torsional rigidity.

The natural frequency can be calculated as:

$$f_n = 1 / 2\pi \cdot \sqrt{C / I}$$

$f_n$ : Natural frequency of coupling in Hz

$C$ : Torsional rigidity of the coupling in Nm/rad

$I$ : Moment of inertia of the rotor in kgm<sup>2</sup>

If radial and/or axial acceleration forces are added, the stiffness of the encoder bearings and the encoder stators are also significant. If such loads occur in the application, please consult Leine & Linde.

### 4.3.11 Magnetic fields

Most of our encoders will not be affected by magnetic fields up to 30 mT. For more information, please contact Leine & Linde.

### 4.3.12 Encapsulation

After a completed encoder installation, all rotating parts must be protected against accidental contact during operation.

For ingress protection information regarding a specific encoder, it is available in the datasheet of the specific encoder model.

The shaft inlet provides protection up to IP67 but may be subject to reduction due to aging of sealing and environmental aspects. Splash water should not contain any substances that would have harmful effects on the encoder parts. If the standard protection of the shaft inlet is not sufficient (such as when the encoders are mounted vertically), additional labyrinth seals should be provided. The sealing rings used to seal the shaft are subject to wear due to friction, the amount of which depends on the specific application. Please contact Leine & Linde if solutions with higher protection are required.

### 4.3.13 Surface treatment

The normal surface treatment used on all encoder parts is either paint or anodization. Most variants can also be offered in stainless-steel versions upon request. The encoder shaft is always manufactured in stainless steel. Connecting elements may be utilized by other surface treatments.

### 4.3.14 System tests

Encoders from Leine & Linde are usually integrated as components in larger systems. Such applications require comprehensive tests of the entire system regardless of the specifications of the encoder.

The specifications given in the catalog apply to the specific encoder, not to the complete system. Any operation of the encoder outside of the specified range or for any other than the intended applications is at the user's own risk.

### 4.3.15 Assembly

Work steps to be performed and dimensions to be maintained during mounting are specified solely in the mounting instructions supplied with the unit. All data in this catalog regarding mounting are therefore provisional and not binding.

### 4.3.16 Temperature ranges

For the encoder in its packaging, the storage temperature range is  $-30^\circ\text{C}$  to  $+70^\circ\text{C}$ . The operating temperature range indicates the temperature the encoder may reach during operation in the actual installation environment. The function of the encoder is guaranteed within this range (DIN 32878). The operating temperature is measured in the air surrounding the encoder.

### 4.3.17 Power supply

All encoders require a stabilized DC voltage +EV as power supply. Most encoders have a polarity-protected power supply. For encoders with 5 V power supply the permissible ripple content of the dc voltage is:

High-frequency interference  
 $V_{pp} < 250 \text{ mV}$  with  $dV/dt > 5 \text{ V}/\mu\text{s}$ .

Low-frequency fundamental ripple  
 $V_{pp} < 100 \text{ mV}$

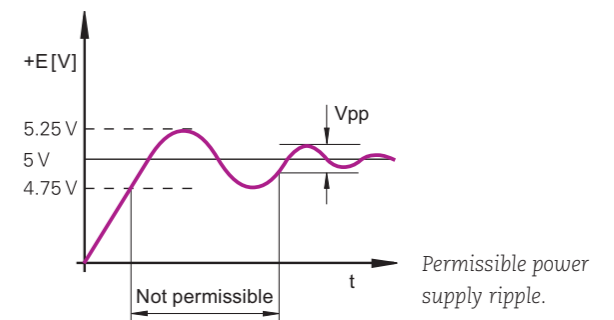

The values apply as measured at the encoder, i.e., without cable influences. The voltage should be monitored and adjusted to ensure proper power supply at the encoder. The voltage drop in the power supply lines can be calculated as:

$$\Delta U = \rho \cdot l \cdot I / A$$

where

$\Delta U$ : Voltage drop

$\rho$ : Resistivity in copper  $0.0175 \text{ ohm mm}^2/\text{m}$  at  $15^\circ\text{C}$

$l$ : Cable length in m

$I$ : Current consumption in A

$A$ : Cross section area of conductor in  $\text{mm}^2$

The encoder housings are isolated against their internal circuits. Rated surge voltage: 500 V (preferred value as per VDE 0110 Part 1, overvoltage category II, contamination level 2).

### 4.3.18 Electrically permissible speed / Traversing speed

The maximum permissible shaft speed or traversing speed of an encoder is derived from the mechanically permissible shaft speed/traversing speed (if listed in the datasheet) and the electrically permissible shaft speed or traversing speed. For encoders with square-wave signals, the electrically permissible shaft speed/traversing speed is limited by the maximum permissible scanning frequency,  $f_{max}$ , of the encoder.

### 4.3.19 Electromagnetic compatibility / CE compliance

When properly installed and when Leine & Linde connecting cables and cable assemblies are used, Leine & Linde encoders fulfill the requirements for electromagnetic compatibility according to 2004/108/EC with respect to the generic standards for industrial environment:

- Immunity IEC 61000-6-2
- Emission IEC 61000-6-4

Noise voltages arise mainly through capacitive or inductive transfer. Electrical noise can be introduced into the system over signal lines and input or output terminals and should always be avoided. Possible sources of noise are:

- Strong magnetic fields from transformers and electric motors
- Relays, contactors and solenoid valves
- High-frequency equipment, pulse devices, and stray magnetic fields from switch-mode power supplies
- AC power lines and supply lines to the above devices

### 4.3.20 Protection against electrical noise

The following measures must be taken to ensure disturbance-free operation:

- Use only Leine & Linde cables
- Use connectors or terminal boxes with metal housings
- Do not conduct any extraneous signals
- Connect the housings of the encoder, connector, terminal box and evaluation electronics through the shield of the cable
- Connect the shielding in the area of the cable inlets to be as induction-free as possible (short, full-surface contact)
- Connect the entire shielding system with the protective ground
- Prevent contact of loose connector housings with other metal surfaces

- The cable shielding has the function of an equipotential bonding conductor

Sufficient decoupling from interference signal-conducting cables can usually be achieved by an air clearance of 100 mm or, when cables are in metal ducts, by a grounded partition. A minimum spacing of 200 mm to inductors in switch-mode power supplies is required.

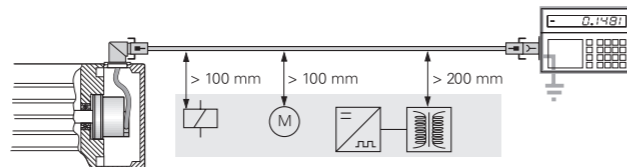

Potential sources causing interference.

When using multiturn encoders in electromagnetic fields greater than 30 mT, please consult Leine & Linde.

Both the cable shielding, the metal housings of encoders and subsequent electronics have a shielding function. It is recommended that the housings have the same potential and are connected to the main signal ground over the machine chassis or by means of a separate potential compensating line. Potential compensating lines should have a minimum cross section of 6 mm<sup>2</sup> (Cu).

### 4.3.21 Cables

The permissible cable lengths listed apply only for Leine & Linde cables and the recommended input circuitry of the subsequent electronics.

The cable type is normally polyurethane, PUR cables or PVC depending on encoder model. PUR cables are resistant to oil, hydrolysis and microbes in accordance with VDE 0472 and most cables comply with UL safety directives.

Standard Leine & Linde cables can be used in a rigid configuration between -40 to 85°C and in frequent flexing between -10 to 85°C. High-temperature cables are available upon request and shall be used when the permissible temperature of the encoder exceed 85°C.

### 4.3.22 Bending radius

The permissible bending radius  $R$  depends on the cable type, the configuration (flexible or rigid installation) and surrounding temperature. Normative values for standard cables are shown in the picture.

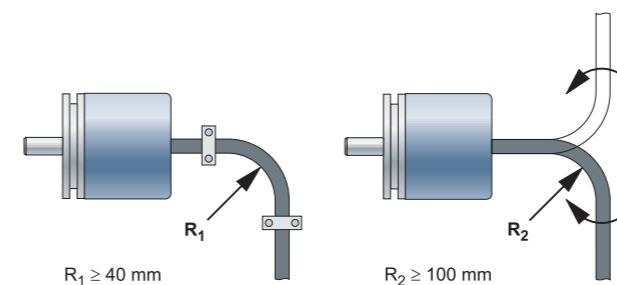

Permissible bending radius for standard cables.



## 5 Interfaces

### 5.1 Incremental interfaces

#### 5.1.1 TTL electronics / RS422

Incremental TTL-signals are transmitted as digital squarewave pulse trains S00 and S90, phase-shifted by 90 el°. The reference mark signal consists of one reference pulse denoted as Sref, which is gated with the incremental signals. As an option on TTL-encoders, the integrated electronics also produce inverse signals of S00 and S90 for noiseproof differential transmission. In this case the encoder signals comply with the RS422 standard.

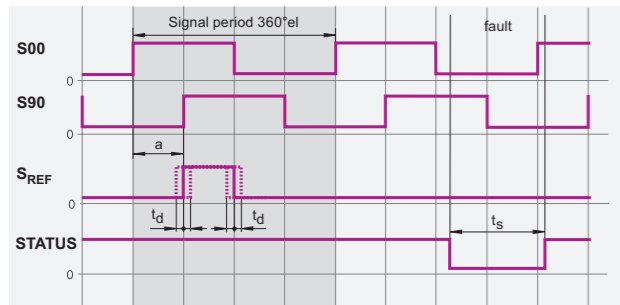

Output signals, TTL electronics.

Interface	Square-wave TTL or RS422 (differential)
Incremental signals	S00, S90 (optional $\overline{S00}$ , $\overline{S90}$ )
Reference mark	Sref (optional $\overline{Sref}$ )
Pulse width	90 el° (other on request)
Delay time	$t_d < 50$ ns
STATUS (optional)	Improper function: Low Proper function: High
Pulse width	$t_s > 20$ $\mu$ s
Signal level	$U_h > 3$ V with $-I_h = 10$ mA $U_l < 0.4$ V with $I_l = 10$ mA
Permissible load	$Z_0 = 100$ W $I_l < \pm 20$ mA (per output) Clod $< 1000$ pF Outputs are short-circuit protected max. 1 min against 0V and +EV
Switching times (10% to 90%)	$t_+/t_- < 200$ ns With 1 m cable and recommended input circuitry

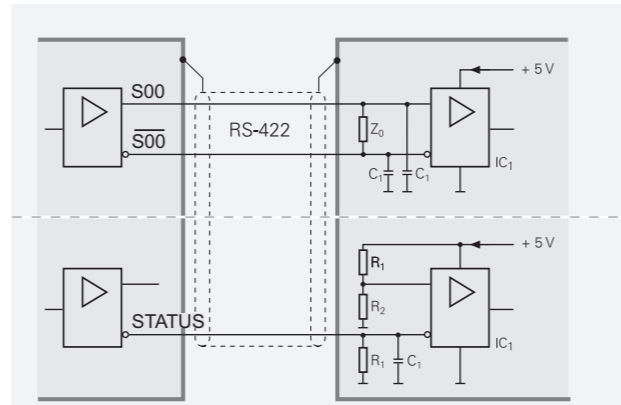

Recommended subsequent electronics, TTL / RS422.

The permissible cable length for transmission of the TTL square-wave signals to the subsequent electronics depends on the edge separation and whether differential (6 channels) or single-ended transmission is used. Note that the permissible cable length is calculated as long as the power supply can be ensured at the encoder. Make sure to compensate for voltage drop in the power supply lines.

**Note:** Leine & Linde encoders equipped with TTL output comply to the RS422 standard when differential signals (6 channels) are used.

#### 5.1.2 HTL and HCHTL electronics

Leine & Linde encoders with HTL interface incorporate electronics that digitize sinusoidal scanning signals. The incremental signals are transmitted as digital square-wave pulse trains S00 and S90, phase-shifted by 90 el°. The reference mark signal consists of one reference pulse Sref, which is gated with the incremental signals. In addition, the integrated electronics produce inverse signals of S00 and S90 for noise proof differential transmission. The fault-detection signal STATUS indicates fault conditions such as under voltage of the power supply or failure of the light source. It can be used for such purposes as machine shutoff during automated production.

To prevent counting error, the subsequent electronics should be designed to process as little as 90% of the edge separation  $a$ . See diagram on next page.

The permissible cable length for incremental encoders with HTL signals depends on the scanning frequency, the effective power supply and the operating temperature of the encoder.

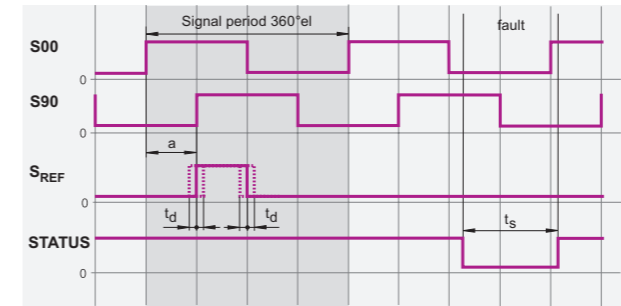

Output signals, HTL / HCHTL electronics.

Interface	HTL or HCHTL
Incremental signals	S00, S90 (optional $\overline{S00}$ , $\overline{S90}$ )
Reference mark	Sref (optional $\overline{Sref}$ )
Pulse width	90 el° (other on request)
Delay time	$t_d < 50$ ns
STATUS (optional)	Improper function: Low Proper function: High
Pulse width	$t_s > 20$ $\mu$ s
Signal level	$U_h > 21$ V with $-I_h = 20$ mA $U_l < 2.8$ V with $I_l = 20$ mA
Permissible load	$Z_0 = \pm 40$ mA $I_l < \pm 100$ mA (per output) Clod $< 10$ nF Outputs are short-circuit protected max. 1 min against 0V and +EV
Switching times (10% to 90%)	$t_+/t_- < 200$ ns With 1 m cable and recommended input circuitry

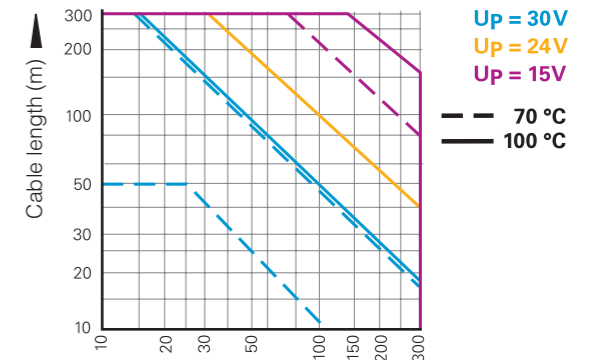

The graph shows the permissible cable length at various frequencies for HTL encoders.

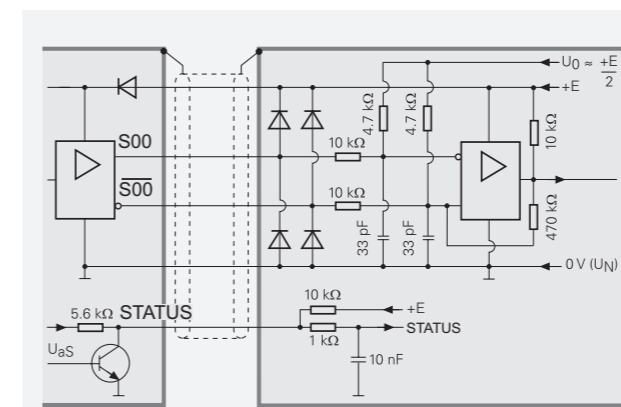

Recommended subsequent electronics, HTL.

## 5.2 Incremental signals 1 Vpp

Leine & Linde encoders with 1 Vpp interface provide voltage signals that can be highly interpolated. The sinusoidal **incremental signals** A and B are phase-shifted by 90° el. and have an amplitude of typically 1 Vpp. The illustrated sequence of output signals - with B lagging A - applies to the direction of motion shown in the dimension drawing.

The **reference mark signal** R has a usable component G of approx. 0.5 V. Next to the reference mark, the output signal can be reduced by up to 1.7 V to a quiescent value H. This must not cause the subsequent electronics to overdrive. Even at the lowered signal level, signal peaks with the amplitude G can also appear.

The data on **signal amplitude** apply when the power supply given in the specifications is connected to the encoder. They refer to a differential measurement at the 120-ohm terminating resistor between the associated outputs. The signal amplitude decreases with increasing frequency. The **cutoff frequency** indicates the scanning frequency at which a certain percentage of the original signal amplitude is maintained:

- -3 dB  $\triangleq$  70 % of the signal amplitude
- -6 dB  $\triangleq$  50 % of the signal amplitude

The data in the signal description apply to motions at up to 20% of the -3 dB cutoff frequency.

### 5.2.1 Interpolation / Resolution / Measuring step

The output signals of the 1 Vpp interface are usually interpolated in the subsequent electronics in order to attain sufficiently high resolutions. For **speed control**, interpolation factors are commonly over 1000 in order to receive usable speed information even at low speeds.

Measuring steps for **position measurement** are recommended in the specifications. For special applications, other resolutions are also possible.

### 5.2.2 Short-circuit stability

A temporary short circuit of one signal output to 0 V or +EV does not cause encoder failure, but it is not a permissible operating condition.

Short circuit at	20 °C	125 °C
One output	< 3 min	< 1 min
All outputs	< 20 s	< 5 s
Interface	Sinusoidal voltage signals 1 Vpp	
Incremental signals	2 nearly sinusoidal signals A and B <ul style="list-style-type: none"> <li>• Signal amplitude M: 0.6 to 1.2 Vpp; typically 1 Vpp</li> <li>• Asymmetry  P - N /2M: &lt; 0.065</li> <li>• Signal ratio <math>M_A/M_B</math>: 0.8 to 1.25</li> <li>• Phase angle <math> \phi_1 + \phi_2 /2</math>: 90° <math>\pm</math> 10° el.</li> </ul>	
Reference-mark signal	One or more signal peaks R <ul style="list-style-type: none"> <li>• Usable component G: <math>\geq 0.2</math> V</li> <li>• Quiescent value H: <math>\leq 1.7</math> V</li> <li>• Switching threshold E, F: 0.04 to 0.68 V</li> <li>• Zero crossovers K, L: 180° <math>\pm</math> 90° el.</li> </ul>	
Connecting cable	Shielded Leine & Linde cable PVC (2 x 5 x 0.25 mm <sup>2</sup> )	
Cable length	Max. 150 m at 90 pF/m distributed capacitance	
Propagation time	6 ns/m	

These values can be used for dimensioning of the subsequent electronics. Any limited tolerances in the encoders are listed in the specifications.

#### Cutoff frequency

Typical signal amplitude curve with respect to the scanning frequency.

### 5.2.3 Input circuitry of the subsequent electronics

#### Dimensioning

Operational amplifier MC 34074

- $Z_0 = 120 \Omega$
- $R_1 = 10 \text{ k}\Omega$  and  $C_1 = 100 \text{ pF}$
- $R_2 = 34.8 \text{ k}\Omega$  and  $C_2 = 10 \text{ pF}$
- $U_B = \pm 15 \text{ V}$
- $U_1$  approx.  $U_0$

#### -3 dB cutoff frequency of circuitry

Approx. 450 kHz  
Approx. 50 kHz with  $C_1 = 1000 \text{ pF}$   
and  $C_2 = 82 \text{ pF}$

The circuit variant for 50 kHz does reduce the bandwidth of the circuit, but in doing so it improves its noise immunity.

#### Circuit output signals

$U_a = 3.48 \text{ Vpp}$  typical  
Gain 3.48

#### Monitoring of the incremental signals

The following sensitivity levels are recommended for monitoring the signal amplitude M:  
Lower threshold: 0.30 Vpp  
Upper threshold: 1.35 Vpp

#### Incremental signals / Reference-mark signal

$R_a < 100 \Omega$ , typically 24  $\Omega$   
 $C_a < 50 \text{ pF}$   
 $\sum I_a < 1 \text{ mA}$   
 $U_0 = 2.5 \text{ V} \pm 0.5 \text{ V}$   
(relative to 0 V of the power supply)

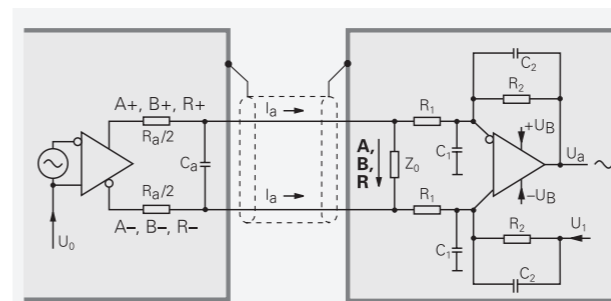

Recommended subsequent electronics, 1Vpp

## 5.3 ADS

### 5.3.1 ADS Classic



Leine & Linde's ADS Classic system has been developed to permit the early detection of fault functions internally in rotating incremental pulse encoders on the 800 series.

The system is based on a rapid logic in conjunction with a microprocessor which continuously monitors the encoder's functions and is thus able to detect a fault function at an early stage. This takes place at such an early stage that the encoder can continue to perform its function in the majority of cases, and replacement of the encoder can take place subsequently during a planned maintenance shutdown.

The main control system receives a message from the encoder about a detected fault function via a signal at the encoder's alarm output. This alarm signal is sent to the operator who, with the help of a PC and the analysis software of the diagnostic system, can communicate with the encoder and establish the cause of the indicated fault. The operator is also informed of the frequency, internal temperature and operating period at the time of the fault. External faults can also be detected. The internal signals in the encoder are compared with the signal that is generated in the cable. It is possible in this way, for example, to detect an overload of the output signals from the encoder. The analysis software can also be used to obtain information about the total operating time and the max./min. operating temperature.

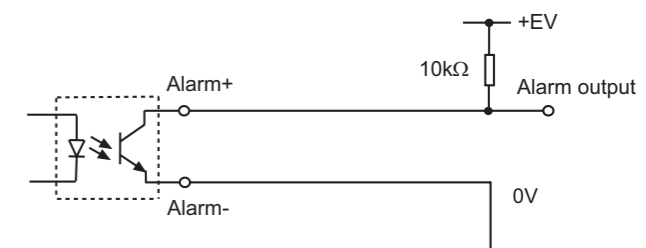
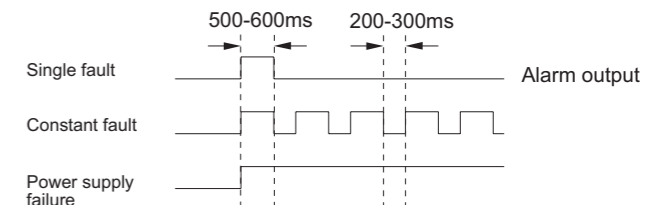

Alarm output.

### 5.3.2 ADS Online



An encoder constitutes a central component for speed feedback, with the entire system being dependent on its function and it is of the utmost importance that it is reliable at all times. The exact service life is difficult to predict since there are many parameters in the environment affecting the encoders life time. The ADS Online is an advanced diagnostics tool that is tailored to supporting condition-based maintenance. The diagnostic system is a feature for the incremental 800 series and it analyses the condition of the encoder and warns of impending faults before they occur, so a replacement of the encoder can take place subsequently during a planned maintenance shut-down.

The encoder is mounted directly on a motor or generator, situated in the middle of the machine's actual operating environment. Because this operating environment affects both the encoder's and machine's service life, it is of interest to gain familiarity with the conditions in the encoder's immediate surroundings.

With ADS Online, the encoder's function is expanded to encompass several sensors in one. The multi-sensor constantly reads off the levels for several environmental parameters in its surroundings.

- Vibration
- Shaft speed
- Frequency
- Temperature
- Supply voltage

It also keeps track of the following values accumulated by the actual encoder unit.

- Revolutions (total number generated)
- Time powered
- Time in motion

An important function in ADS Online is that the system conducts automatic interpretation and analysis of each detected fault. The analysis determines the seriousness of the fault and sorts it into one of four categories based on the encoder's condition. The system also provides notification of a recommended measure that should be taken to prevent problems.

The channels available for communication with the diagnostic system are either visually through the indicator on the encoder, electrically via a signal cable or online for detailed data about encoder status and analysis via PC software.

By connection to the associated PC software, detailed information can be read out for each detected deviation, together with data regarding the ambient environment condition in the moment of the deviation.

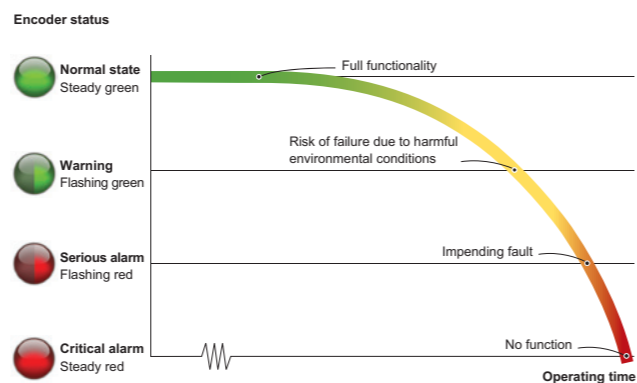

The encoder's various status levels are indicated by an LED in one of four states.

### 5.4 Absolute electrical interfaces

#### 5.4.1 Parallel

Parallel output provides an absolute position available simultaneously on the output. It may be provided as binary or transformed in gray code format. Gray code means a single-bit change between each position step, which can reduce transmission errors.

Parallel output encoders can also accept inputs, for example setting the counting direction.

The advantage of parallel output is that it is fast and all the data is available in real time, all the time.

#### 5.4.2 Analog

The absolute position can also be represented as an analog current output. 0-20 mA or 4-20 mA for a full-scale output.

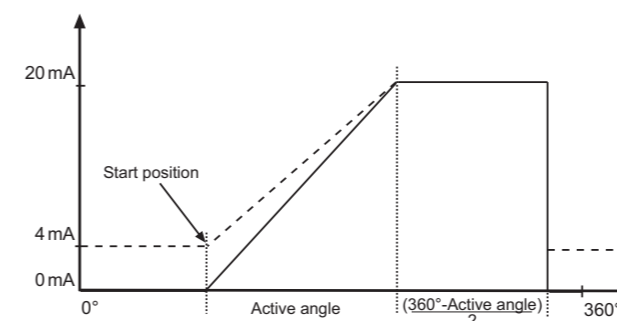

Output signal analog interface.

On special request an analogue output with a teach-in functionality can also be offered. The teach-in function implies that the encoders active angle can be configured at will. A maximal full-scale output 0 or 4-20 mA current value can therefore be distributed over the total measuring range.

#### 5.4.3 BiLL (RS485 based)



BiLL is a bi-directional master/slave communication used on absolute encoders. The protocol can be used for RS485 transmission

standards or for a multi-drop bus system using the RS485 standard. Data are sent in hexadecimal format and the addressed encoder answers only on a master request. The protocol includes position data in binary format, a checksum for transmission reliability, a hold command, a change of baud rate command and an error message.

#### 5.4.4 Serial point-to-point

Serial transmission means that bit information is transmitted sequentially in the same pair of conductors rather than sending each bit in its own conductor as in parallel transmission.

One of the advantages of serial transmission is that installation costs less; fewer wires means less work and less documentation.

There are several more or less standardized methods for serial transmission of data, all with their advantages and disadvantages. The following is a short description of the most common serial standards used for communication with encoders.

#### 5.4.5 EnDat 2.1



The EnDat 2.1 interface is a digital, bidirectional interface for encoders. It is capable of transmitting position values from absolute encoders, as well as reading and updating information stored in the encoder.

Thanks to the serial transmission method, only four signal lines are required. The absolute position data are transmitted in synchrony with the clock signal generated by the subsequent electronics. The type of transmission (position values, parameters, diagnostics, etc.) is selected by mode commands that the subsequent electronics send to the encoder.

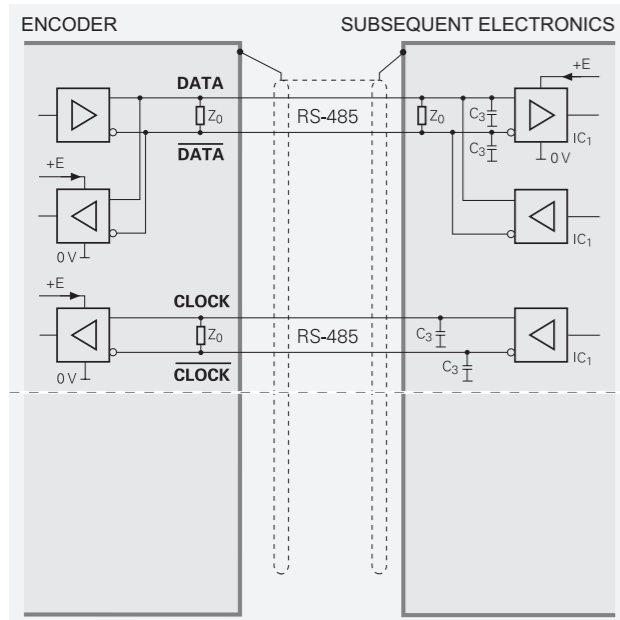

Recommended subsequent electronics.

A clock pulse (CLOCK) is transmitted by the subsequent electronics to synchronize data transmission. When not transmitting, the clock signal defaults to HIGH.

One data packet is sent in synchrony per data transmission. The transmission cycle begins with the first falling clock edge. The measured values are saved and the position value calculated. After two clock pulses ( $2T$ ), the subsequent electronics transmit the mode command "Encoder transmit position value". After successful calculation of the absolute position value ( $t_{cal}$  - see table), the start bit begins the data transmission from the encoder to the subsequent electronics.

Interface	Endat 2.1
Clock frequency $f_c$	100 kHz ... 2 MHz (optional up to 16 MHz)
Calculation time for Position value $t_{cal}$	< 5 $\mu$ s
Recovery time $t_m$ $t_r$	10 to 30 $\mu$ s Max. 500 ns

The encoder then transmits the absolute position value, beginning with the LSB. Its length varies depending on which encoder is being used. The number of required clock pulses for transmission of a position value is saved in the parameters of the encoder manufacturer. The data transmission of the position value is completed with the Cyclic Redundancy Check (CRC).

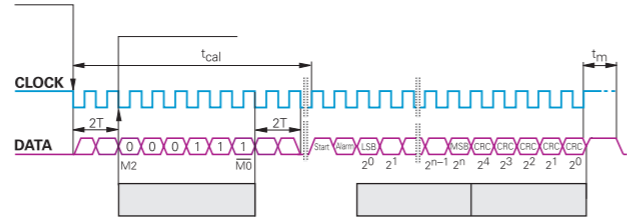

Data transfer EnDat 2.1.

EnDat 2.1 encoders are available with incremental 1Vpp signals.

**Note:** Every Leine & Linde gateway for fieldbus communications communicates with the encoder via the EnDat 2.1 interface.

### 5.4.6 EnDat 2.2

**EnDat 2.2** With EnDat 2.2 it is possible to transfer additional data with the position value without sending a separate request for it. EnDat 2.2 is compatible with EnDat 2.1.

The extended EnDat interface version 2.2 is compatible in its communication, command set and time conditions with the previous version 2.1, but also offers significant advantages. It makes it possible, for example, to transfer what is termed "additional data" with the position value without sending a separate request for it. The interface protocol was expanded and the time conditions were optimized as follows:

- Increased clock frequency (CLOCK) 16 MHz
- Optimized calculating time, position value acquisition within 5  $\mu$ s
- Minimized dead time (recovery time) 1.25 to 3.75  $\mu$ s
- Expanded power supply range, UP = 3.6 to 5.25 V or 3.6 to 14 V at encoder

	Without delay compensation	With delay compensation
Clock frequency $f_c$	100 kHz ... 2 MHz	100 kHz ... 16 MHz
Calculation time for Position value $t_{cal}$	Typical of EnDat 2.2 encoders: $\leq 5 \mu$ s	
Parameter $t_{ac}$	Max. 12 ms	
Recovery time $t_m$	EnDat 2.1: 10 to 30 $\mu$ s EnDat 2.2: 10 to 30 $\mu$ s or 1.25 to 3.75 $\mu$ s ( $f_c \geq 1$ MHz) (parameterizable)	
$t_r$ $t_{ST}$	Max. 500 ns 2 $\mu$ s to 10 $\mu$ s	
Data delay time $t_D$	(0.2 + 0.01 x cable length in m) $\mu$ s	
Pulse width $t_{HI}$	0.2 to 10 $\mu$ s	Pulse width fluctuation HIGH to LOW max. 10 %
$t_{LO}$	0.2 to 50 ms to 30 $\mu$ s (with LC)	

EnDat 2.2 encoders are available with incremental 1 Vpp signals.

For further information about the EnDat interface, please contact Leine & Linde.

### 5.4.7 SSI

SSI or Synchronous Serial Interface, is a digital point-to-point interface. It provides unidirectional communication at speeds up to 1.0 MHz by the use of only 4 wires.

The absolute position value, beginning with the most significant bit, is transferred over the data lines (DATA) in synchrony with a CLOCK signal from the control. The SSI standard data word length for singleturn absolute encoders is 13 bits, and for multiturn absolute encoders 25 bits. The position value is transmitted in gray or binary code format.

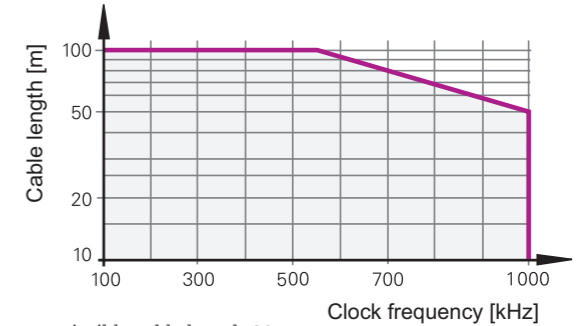

Permissible cable length SSI.

In the quiescent state the clock and data lines are on high level. The current position value is stored on the first falling edge of the clock. The stored data is then clocked out on the first rising edge.

After transmission of a complete data word, the data line remains low for a period of time ( $t_2$ ) until the encoder is ready for interrogation of a new value. If another data output request (CLOCK) is received within this time, the same data will be output once again. If the data output is interrupted (CLOCK = high for  $t > t_2$ ), a new position value will be stored on the next falling edge of the clock, and on the subsequent rising edge clocked out to the subsequent electronics.

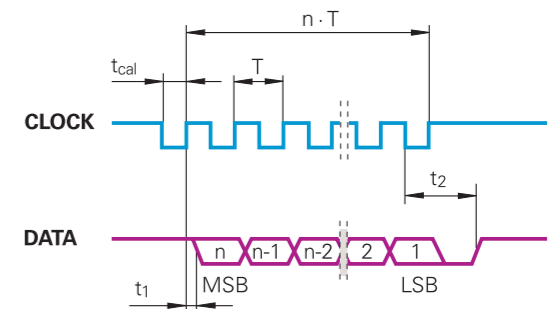

Data transfer SSI.

Interface	SSI
Clock frequency $T$	1 ... 10 $\mu$ s
Calculation time for Position value $t_{cal}$	< 5 $\mu$ s
Recovery time $t_1$ $t_2$ $n$	0.4 $\mu$ s 12 ... 30 $\mu$ s 13 ... 25 bit

For the 600 series encoders, the following functions can be activated via the programming inputs of the interfaces by applying the input to a logic high level, i.e. +EV:

### Direction of rotation

Continuous application of a HIGH level reverses the direction of rotation for ascending position values.

### Zero setting (setting position to zero)

Applying a positive edge ( $t_{min} > 1 \mu s$ ) sets the current position to zero.

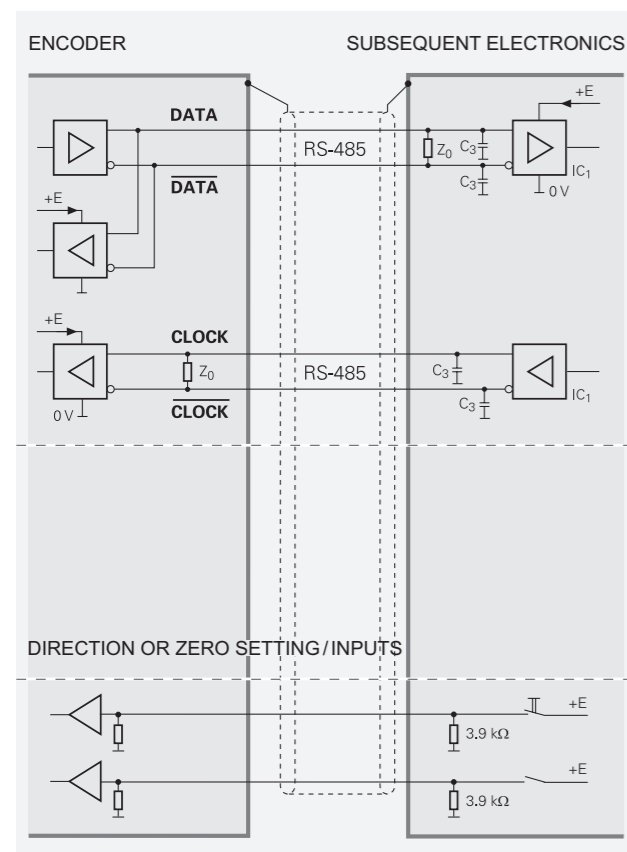

Recommended subsequent electronics.

**Note:** The programming inputs must always be terminated with a resistor (see input circuitry of the subsequent electronics).

The SSI interface is also available in combination with incremental 1 Vpp, HTL or RS422 signals on certain models.

## 5.5 Fieldbus interfaces

### 5.5.1 PROFIBUS DP

**PROFIBUS**® PROFIBUS is a powerful and versatile 2-wire non-proprietary open fieldbus standard defined by several international standards such as EN 50170, IEC 61158 together with different device profiles.

The encoder device profiles for PROFIBUS-DPV0, DPV1 and DPV2 define the functionality of encoders connected to a PROFIBUS-DP bus. There are two encoder profiles available 3.062 and 3.162 defining the functionality of encoder for the different versions of PROFIBUS DP.

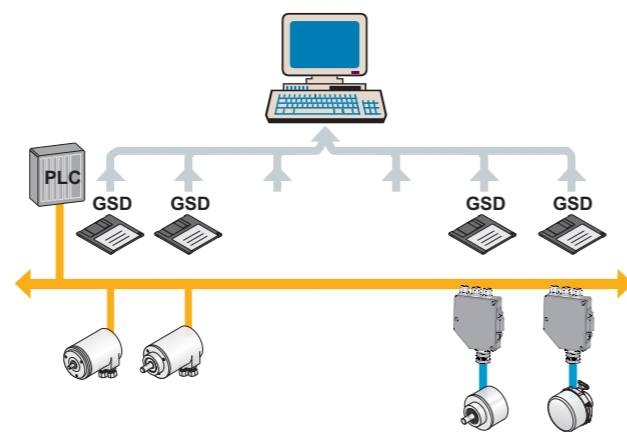

Network and configuration of PROFIBUS.

#### Encoder Profile for DPV0, profile number 3.062

The operating functions in this profile are divided into two device classes. Class 1 encoders offer basic functions that all PROFIBUS-DP encoders must support. An encoder of class 1 can optionally support selected functions of class 2 but these functions must be implemented according to the profile.

Encoders of class 2 must support all functions of class 1 as well as the additional functionality of class 2.

#### Encoder Profile for DPV1 and DPV2, profile number 3.162

In addition to the functionality enabled in DPV0 and acyclic data exchange, expansions to the PROFIBUS were required to enable the interface in time-critical applications. As a result, DP-V2 functionality such as slave-to-slave communication and isosynchronous data exchange was added.

Slave-to-slave communication means, as the name implies, that slaves in a net can exchange information with each other via broadcast messages without communication being initiated by the master. This type of communication is very efficient and fast, which reduces the response time on the bus by up to 90%.

Isosynchronous data exchange implies that the master can reach several slaves simultaneously with for example set point values, or receives feedback values from different slaves. With the isosynchronous mode, a system can be set up where all slaves set their output values and read their input values at the same time with a very high accuracy. This functionally results in synchronization between many different slaves within 1  $\mu s$ .

For further information regarding the Encoder functionality refer to the device profiles. These profiles and PROFIBUS technical information can be ordered at PNO in Karlsruhe, Germany ([www.PROFIBUS.com](http://www.PROFIBUS.com)).

To choose between the different profile versions different GSD files are available. The user can select the version that fits their hardware and software. The different GSD file can be downloaded from [www.leinelinde.com](http://www.leinelinde.com).

#### Encoder functionality

The encoder can be configured as a class 1, 2 (DPV0) or class 3 or 4 (DPV2) PROFIBUS slave device. Class 2 configuration is extended to optionally access speed information from the encoder.

In the basic class 1 or 3 configuration only output values/positions are available.

The following functions can be performed or programmed:

- Position read out
- Changed direction of counting
- Diagnostic data up to octet 16

The following functions are available in addition on the class 2 or 4 functions:

- Scaling function
- Preset Value Function
- Speed read-out (class 2)
- Extended diagnostic data

### 5.5.2 PROFINET IO

**PROFINET**® PROFINET is an open standard for industrial Ethernet and uses TCP/IP and IT standards. This fieldbus interface satisfies all requirements for automation technology and it is widely used within factory automation and process automation. PROFINET IO describes an I/O data view of distributed I/O. It includes real-time (RT) communication and isochronous real-time (IRT) communication for cyclic process data. PROFINET is standardized in IEC 61158 and IEC 61784.

Leine & Linde PROFINET encoders conform to the encoder profile v4.1 (3.162) for PROFIBUS and PROFINET. The encoder profile version 4.1 is a further development of the encoder profile for DPV2 encoders' version 3.1. It includes all the encoder functionality from encoder profile version 3.1 but it has been expanded with the usage of encoders with PROFINET and additionally the definition of a 64 bit position value.

Application class definition:

#### Class 3

Encoder with base-mode parameter access and limited parameterization of the encoder functionality. Isochronous mode is not supported.

#### Class 4

Encoder with scaling, preset, code sequence and base mode parameter access. Isochronous mode (IRT) is supported.

The GSDML file can be downloaded from [www.leinelinde.com](http://www.leinelinde.com).

### 5.5.3 CANopen

**CANopen**® The CANopen communication profile is based on the CAN Application Layer (CAL) specification from the CiA (CAN in Automation). CANopen is regarded as a robust fieldbus with highly flexible configuration possibilities. It is used in many various applications all based on different application profiles.

CANopen comprises a concept to configure and communicate real-time data using both synchronous and asynchronous messages. Four types of messages (objects) are distinguished:

1. Administrative messages (Layer Management, Network Management, etc.)
2. Service Data Messages (SDO)
3. Process Data Messages (PDO)

#### 4. Pre-defined Messages (Synchronization-, Time-stamp-, Emergency Messages)

For further information please view the CANopen specification available at [www.can-cia.org](http://www.can-cia.org).

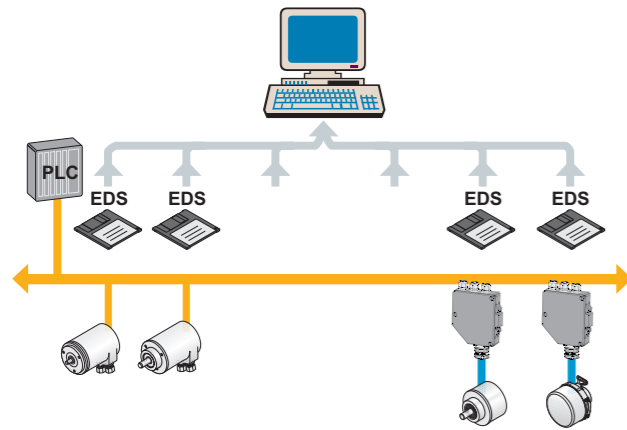

Network and configuration of CAN.

The Encoder Profile defines the functionality of encoders connected to CANopen. The operating functions are divided into two device classes:

##### Class 1

The Mandatory class with a basic range of functions that all encoders must support. The class 1 encoder can optionally support selected class 2 functions, these functions must however be implemented according to the profile.

##### Class 2

Where the encoder must support all class 1 functions and all functions defined in class 2. The full class 2 functionality includes:

- Absolute position value transfer using either polled, cyclic or sync mode
- Speed and acceleration output values
- Change of code sequence
- Preset value settings
- Scaling of the encoder resolution

Advanced diagnostics including:

- Encoder identification
- Operating status
- Operating time
- Alarms and warnings

All programming and diagnostic parameters are accessible through SDO's. The output position value from the encoder is presented in a binary format.

### 5.5.4 DeviceNet



DeviceNet is a low-level network that provides connections between simple industrial devices (sensors, actuators) and higher-level devices (controllers). DeviceNet provides Master/Slave and Peer-to-Peer capabilities over the CAN bus.

DeviceNet has two primary purposes:

- Transport of control-oriented information associated with low-level devices
- Transport of other information, which is indirectly related to the system being controlled, such as configuration parameters

A DeviceNet node is modelled as a collection of Objects. An Object provides an abstract representation of a particular component within a product. The realization of this abstract object model within a product is implementation-dependent. In other words, a product internally maps this object model in a fashion specific to its implementation.

Like all other fieldbus interfaces, there is also an Encoder Profile which defines the functionality of encoders connected to a DeviceNet network. In the Encoder Profile are all Objects described that are used from DeviceNet Object library. Particular interesting is the Position Sensor Object (0x23 Hex). It describes the services that are available for fetching positions, scaling of position values and other useful information.

The full profile describes the encoder functionality which includes:

- Absolute position value transfer
- Speed output values
- Change of code sequence
- Preset value settings
- Scaling of the encoder resolution

Advanced diagnostics including:

- Encoder identification
- Operating status
- Operating time
- Alarms and warnings

The Encoder Profile is a description of the objects and functions available to the user, and is available on [www.leinelinde.com](http://www.leinelinde.com).

### 5.5.5 DRIVE-CLiQ



DRIVE-CLiQ is an Ethernet-based communication protocol from Siemens for connection of sensors. This interface is specially made for drive applications for an easy connection between components such as converters, motors

and sensors. With a speed of 100 Mbit/s and a cycle time of 31.25  $\mu$ s, DRIVE-CLiQ has the performance required for the most demanding applications. Components with DRIVE-CLiQ can be automatic configured with each other since every component has an electronic label to store component-specific data used during commissioning drive systems. Another characteristic with the protocol is that the cabling onsite is reduced. Up to five units may be connected to a hub for transfer of data over a common cable. The Drive-CLiQ encoders are designed for transfer of both speed and position and are supplied with specially adapted connectors, with power supply and data in the same connector making it easy to connect the encoders.



The best encoders are those you never have to think about. Those that simply do their job – year after year. Leine & Linde develops and manufactures customised encoder solutions for demanding environments, advanced measuring systems for accurate feedback of speed and position.

**LEINE  LINDE**

+46-(0)152-265 00 [www.leinelinde.com](http://www.leinelinde.com)